



21.5 inch rugged display

The Hlink-215CS-BS is a versatile display with HDMI/VGA/USB(optional) input that can be mounted into a cutout in an enclosure. The front panel is made of aluminum panel, which is rugged and durable, it can also be equipped with optional low-temperature heating components, programmable bezel pushbuttons, optical bonding of protective glass, touch screen, EMI filtering, and custom anti-reflective/anti-glare AR/AG coatings.

The power input is a wide range 9~36VDC power input for applications. The same model is available in screen sizes up to 55". This monitor can be connected to a rugged fanless PC.

Specifications:

- Resolution with 1920 x 1080
- Brightness: 450 cd/m², Optional High Brightness that can reach 1200cd/m²
- Horizontal/Vertical Viewing Angle: $\pm 89^\circ$ H / $\pm 89^\circ$ V
- Optional Wide Range DC 9~36V Power Input
- Power consumption: 19 W typical, 45 W maximum (Configure heating components)
- IP65 Compliant Front Panel
- Touchscreen (Optional)
- Optical bonding (Optional)
- NVIS support (Optional)
- EMI mesh filter (Optional)
- PCB conformal coating for protecting circuitry in harsh environments
- Heater for protection at low temperatures with -40°C (Optional)
- Customized housing and optional monitor handles (Optional)
- Image enhancement technology

Environmental Requirements:

- Operating Temperature: -20 to 55°C
- Non-Operating Temperature: -40 to 71°C
- Operating Humidity: 95% R.H. @max. 40°C
- Vibration: MIL-STD-810G
- Shock: MIL-STD-810G
- EMI/EMC: MIL-STD-461/462
- Operating Altitude: 0 to 4000 ft

Application Environment:

- Ground Vehicles (✓)
- Ships (✓)
- Aircraft (✗)

Dimensions:

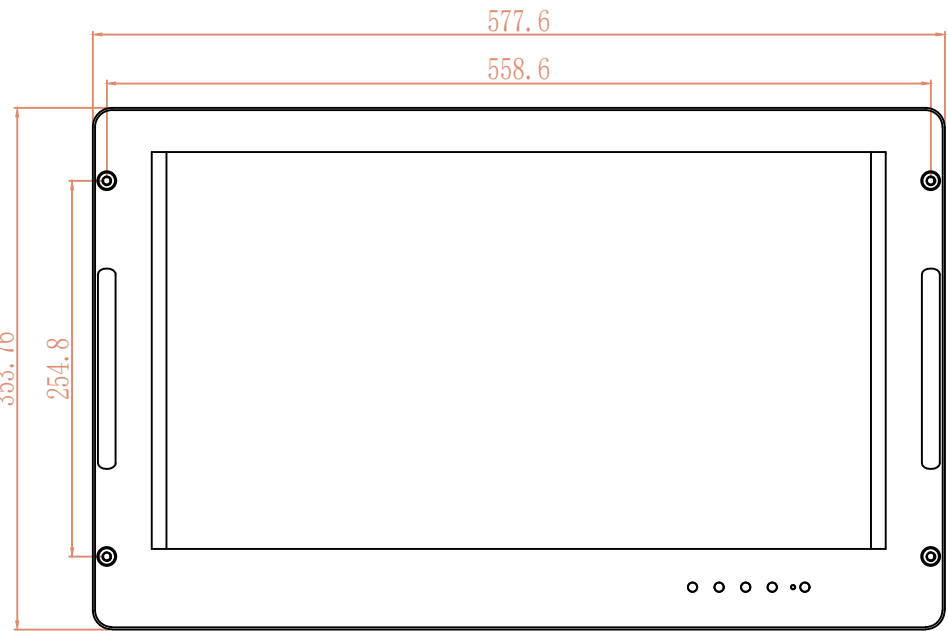
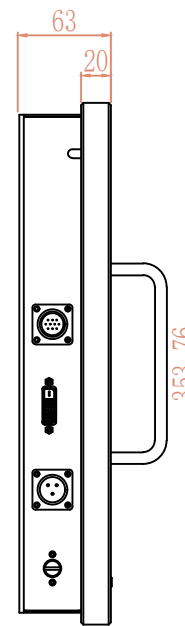
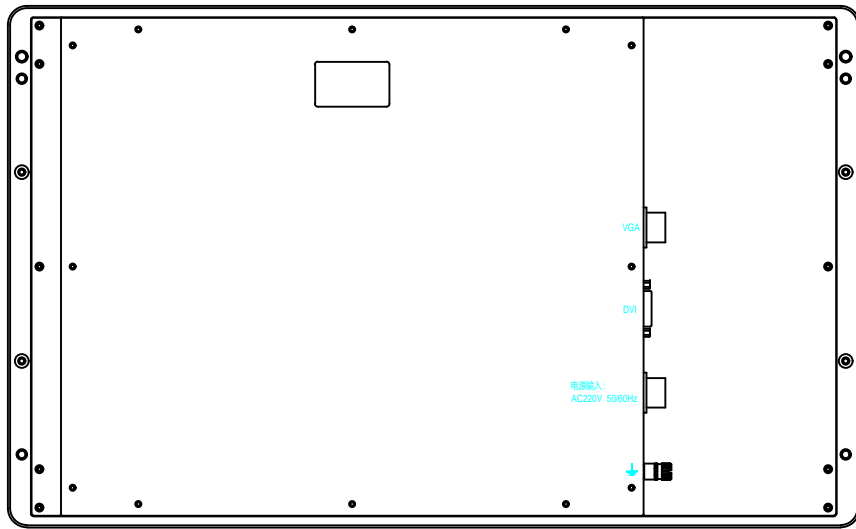

Monitor dimensions

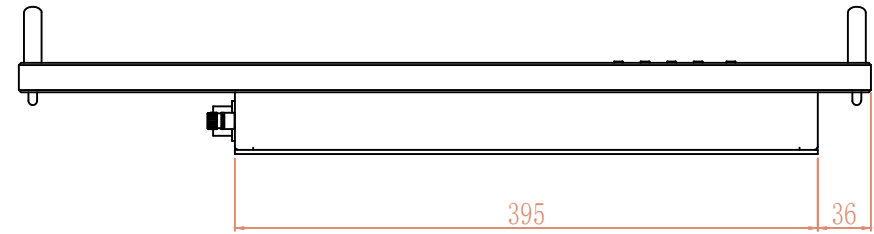
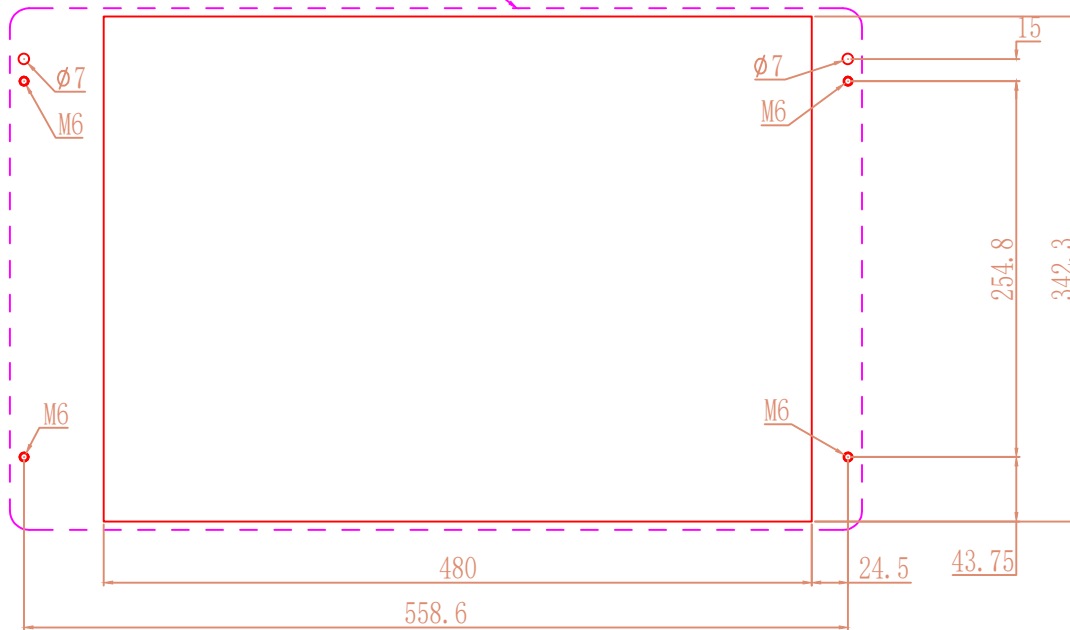

window cutting size