

Conveyor Lighting Stand Installation Instructions

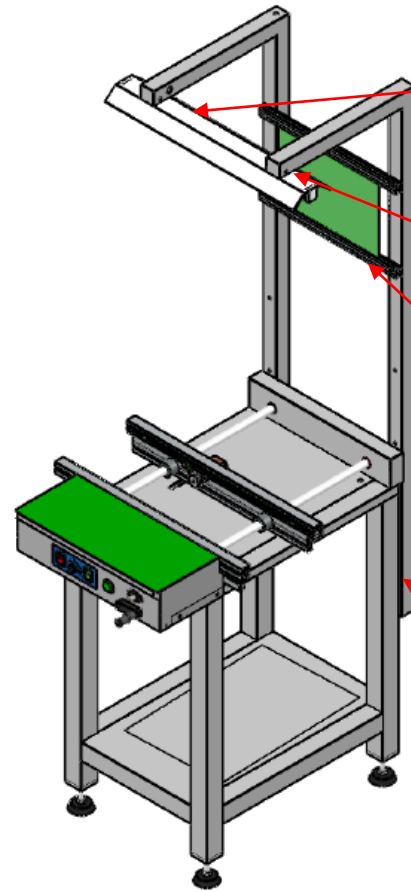

Step 4 :power wire connection installation

Step 3:Installing lamp holder

Step 2 :Installing the intermediate bracket

Step 1 :Install the bottom bracket

Detailed list of accessories(1.5M Conveyor)

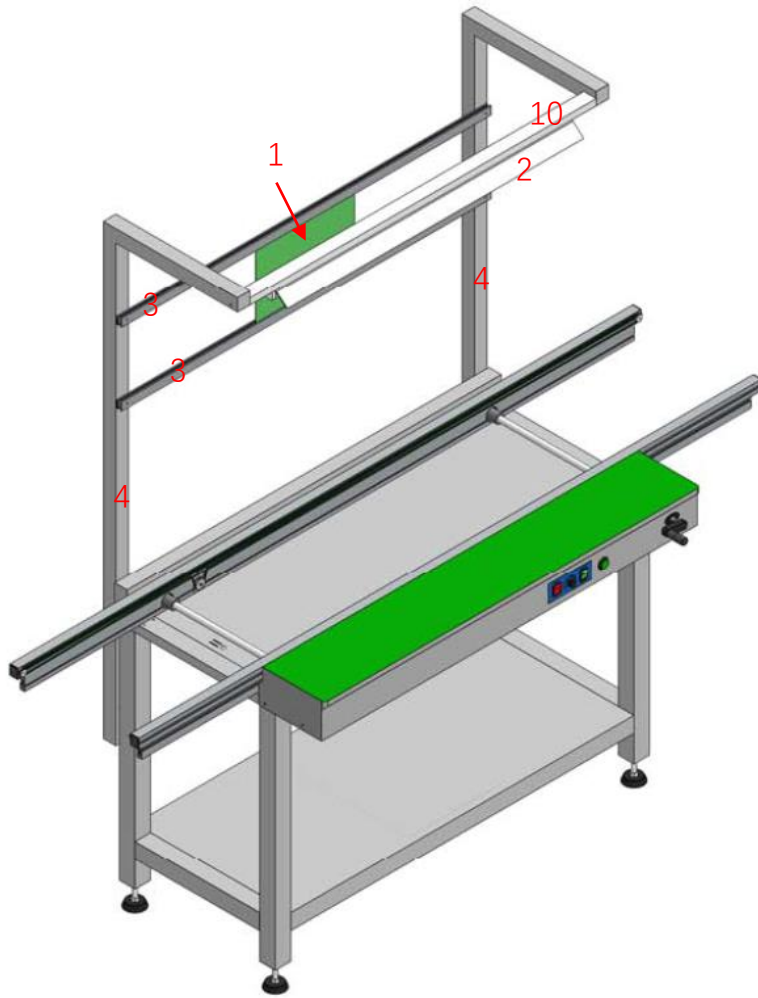

Item	P/N	Name	size	Quantity
1	SC4EDZ021	1.A4 Hard rubber sleeve	A4	1
2	SC4EDZ022	Energy saving lamp	1.2M	1
3	SC4EDZ023	intermediate bracket	1.2M	2
4	SC4EDZ024	Square light stand	1.2M	2
5	SC4EDZ025	M6x65 screws	M6x65	4
6	SC4EDZ066	M6x50 screws	M6x50	2
7	SC4EDZ027	M4x20 screws	M4x20	4
8	SC4EDZ028	M4x10 screws	M4x10	2
9	SC4EDZ029	Light Power wire	1M	2
10	SC4EDZ0030	Top bracket	1.09M	1

Step 1 :Install the bottom bracket

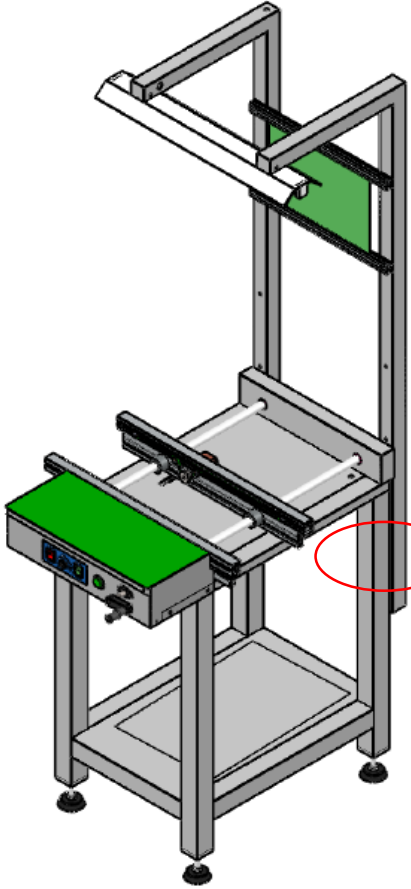

Secure the base bracket with 4 M6x65 screws
2 Square light stand

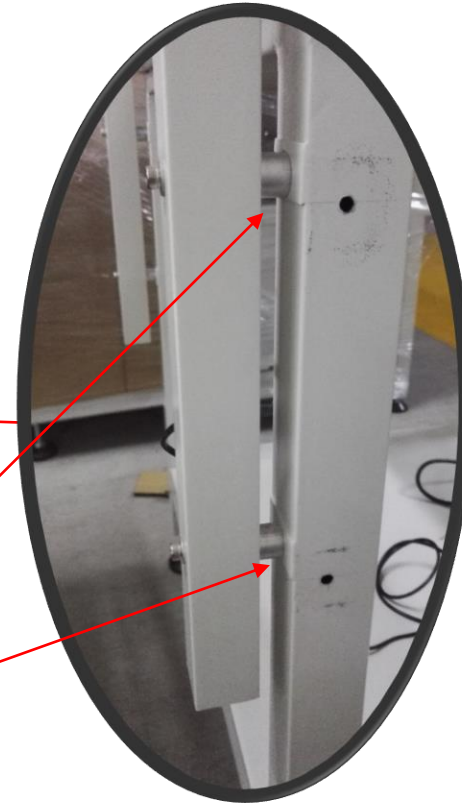

Step 2 :Installing the intermediate bracket

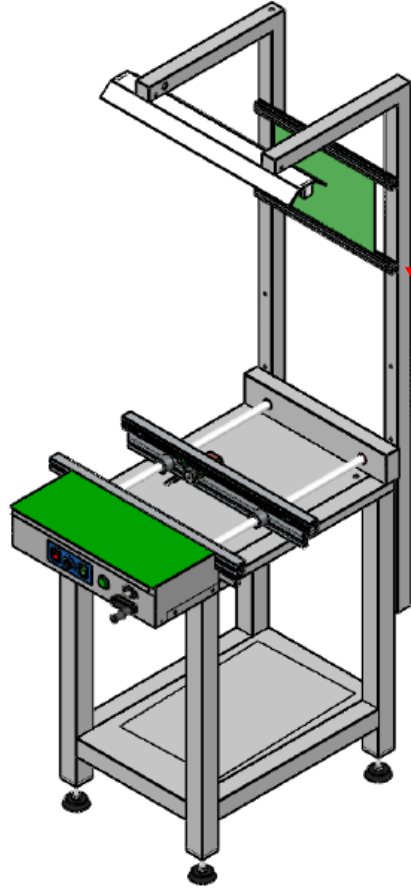

Secure the intermediate bracket with 4
M4x20 screws

2 intermediate bracket *1.2m

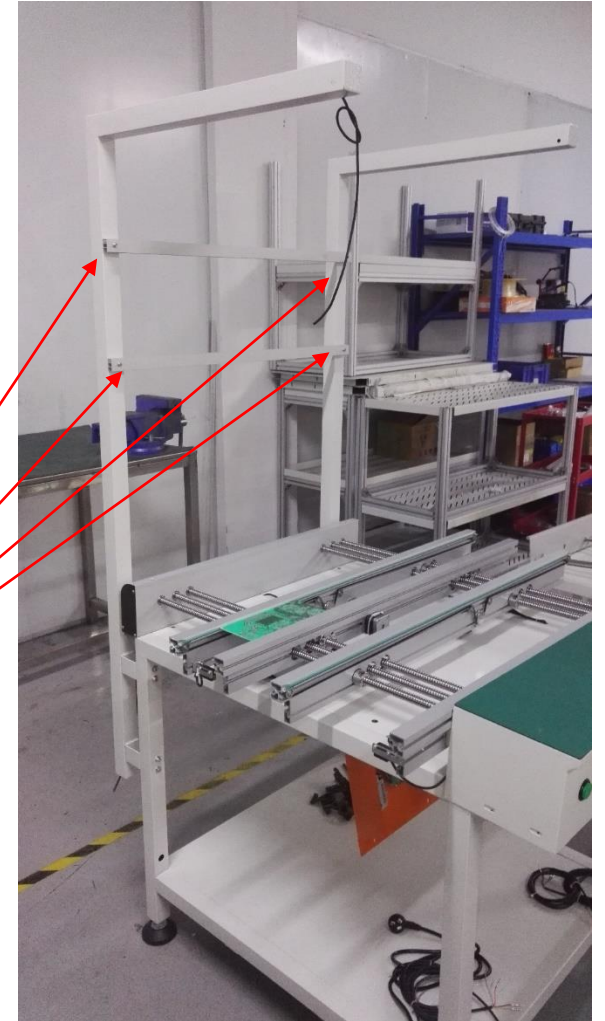
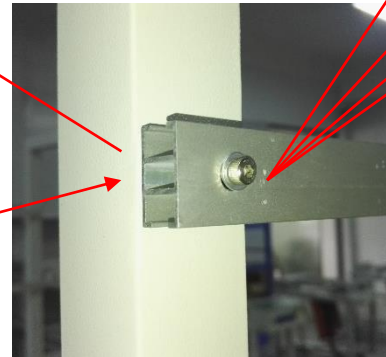

Step 3: Installing lamp holder

3.1 Use two M6X50 screws on the top to mount a 1.09 m bracket.

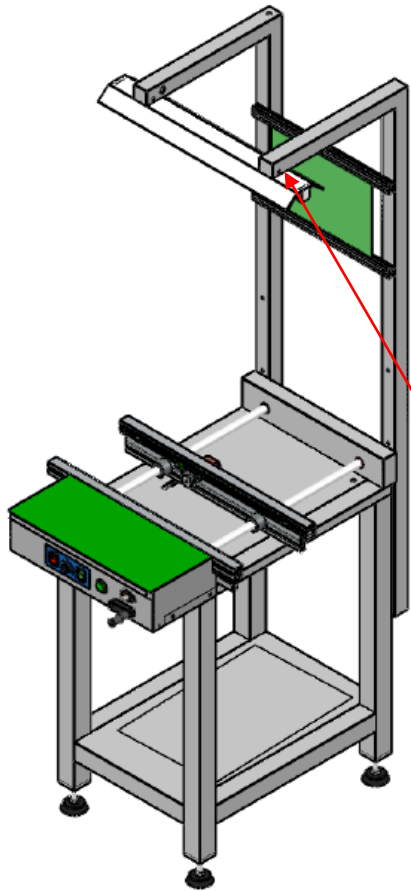

Top bracket

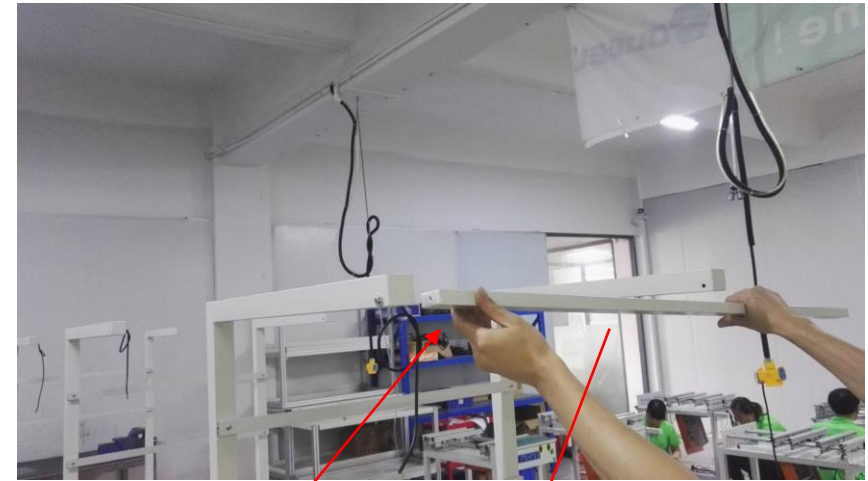

Length 1.09m Top bracket



Step 3: Installing lamp holder

3.2 Lamp holder connector installation method

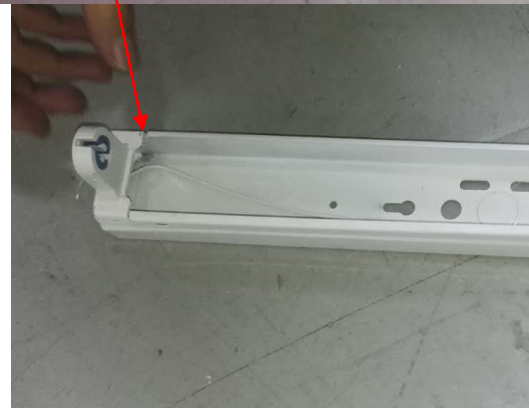
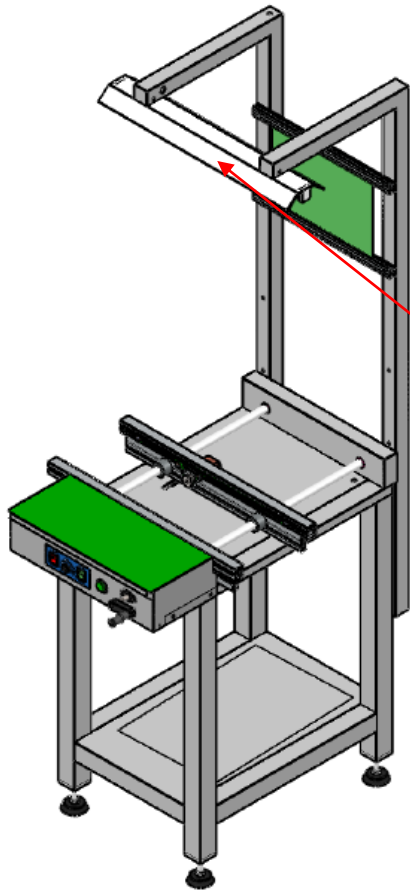

Step 3: Installing lamp holder

3.3 Fix the lamp holder to the bracket with M4X10 screws

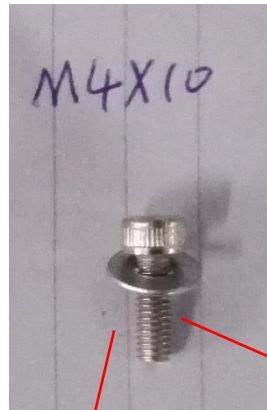
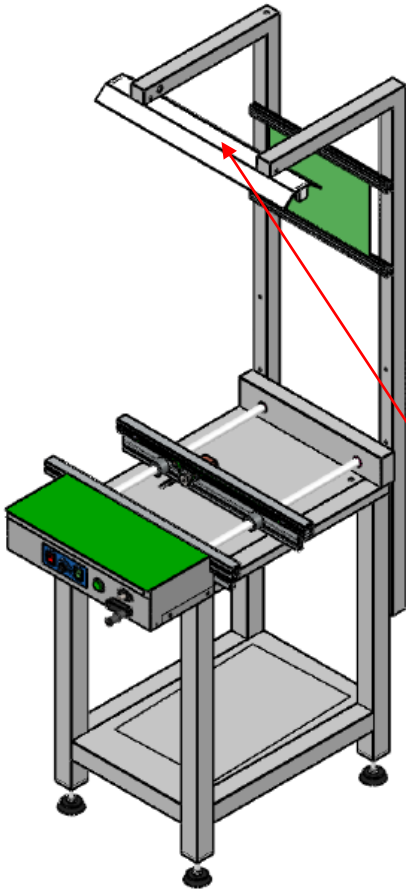

Step 3: Installing lamp holder

3.4 Light 110V power cable connection

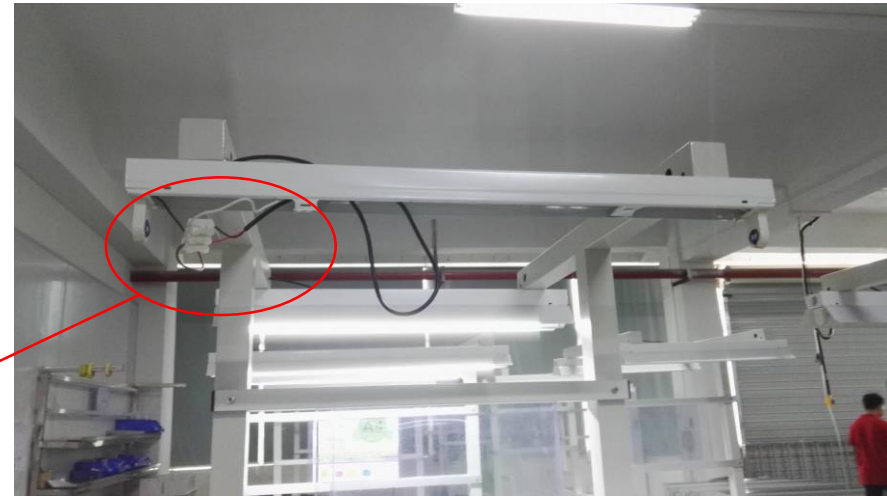
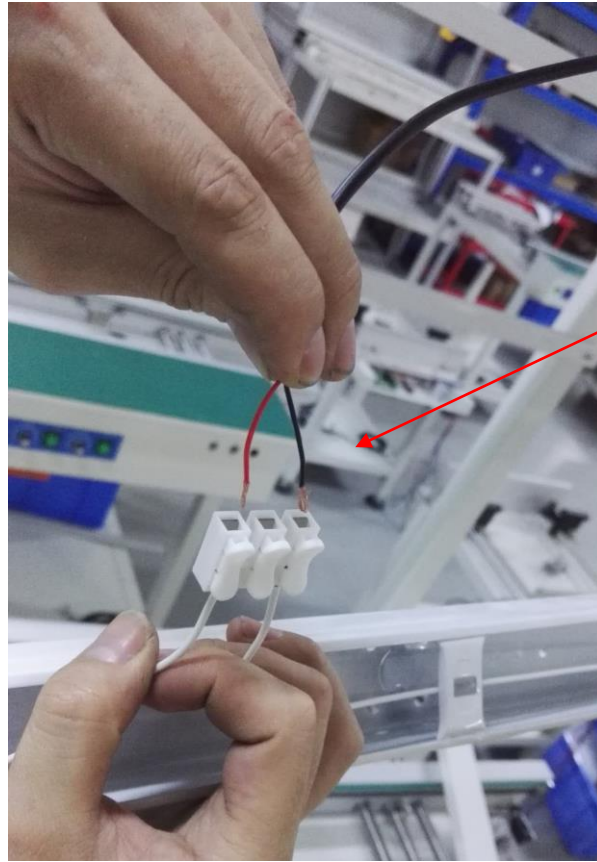
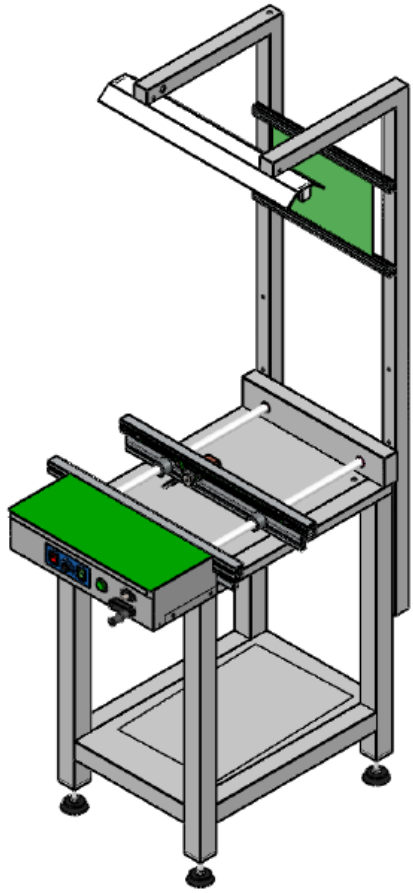

Step 3: Installing lamp holder

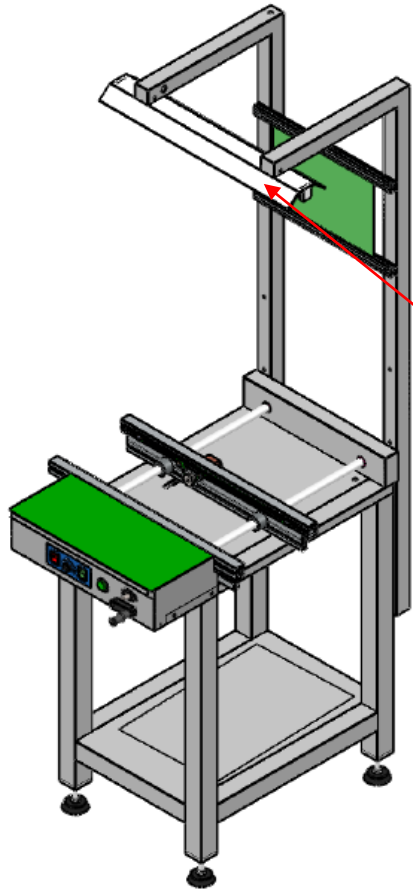

3.5 Lamp cover

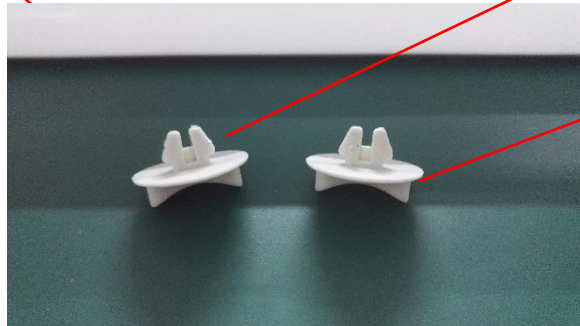

Step 4 :power wire connection installation

4.1, originally with a light, the machine has a terminal inside, you can directly connect the lamp holder power

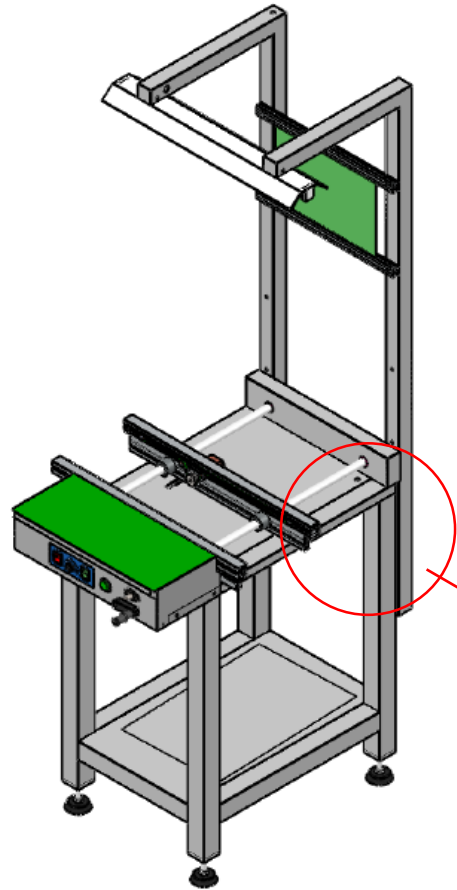

the machine has a terminal inside



Step 4 :power wire connection installation

4.2, originally without a light, the new light stand, should be directly connected to the internal power supply terminal block

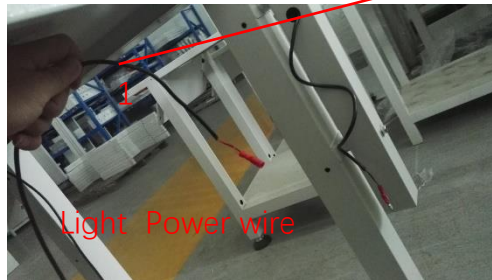
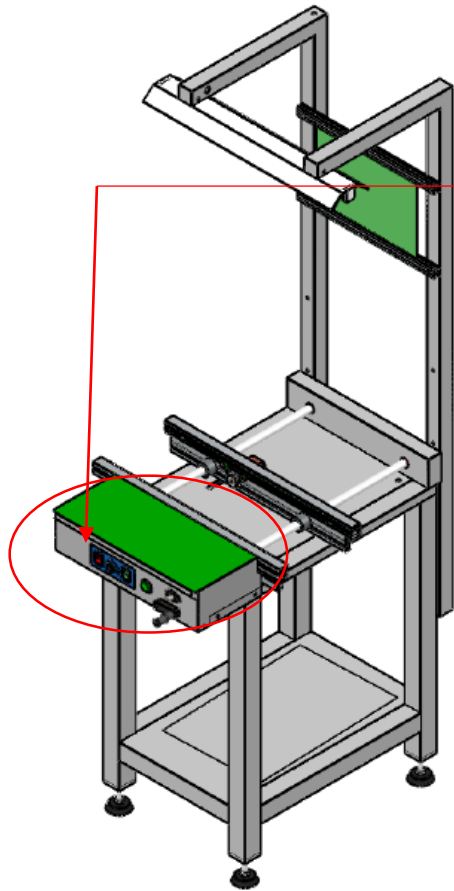

Light Power wire

Use new wire connection

Red wire to L, black wire to N

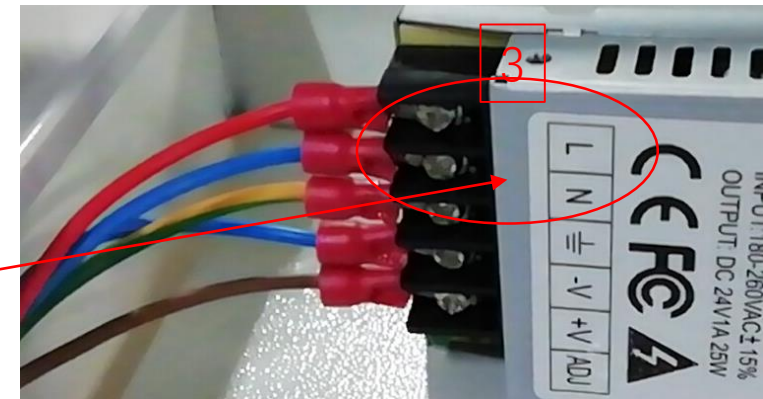

L N -V +V ADJ