

Conveyor Lighting Stand Installation Instructions

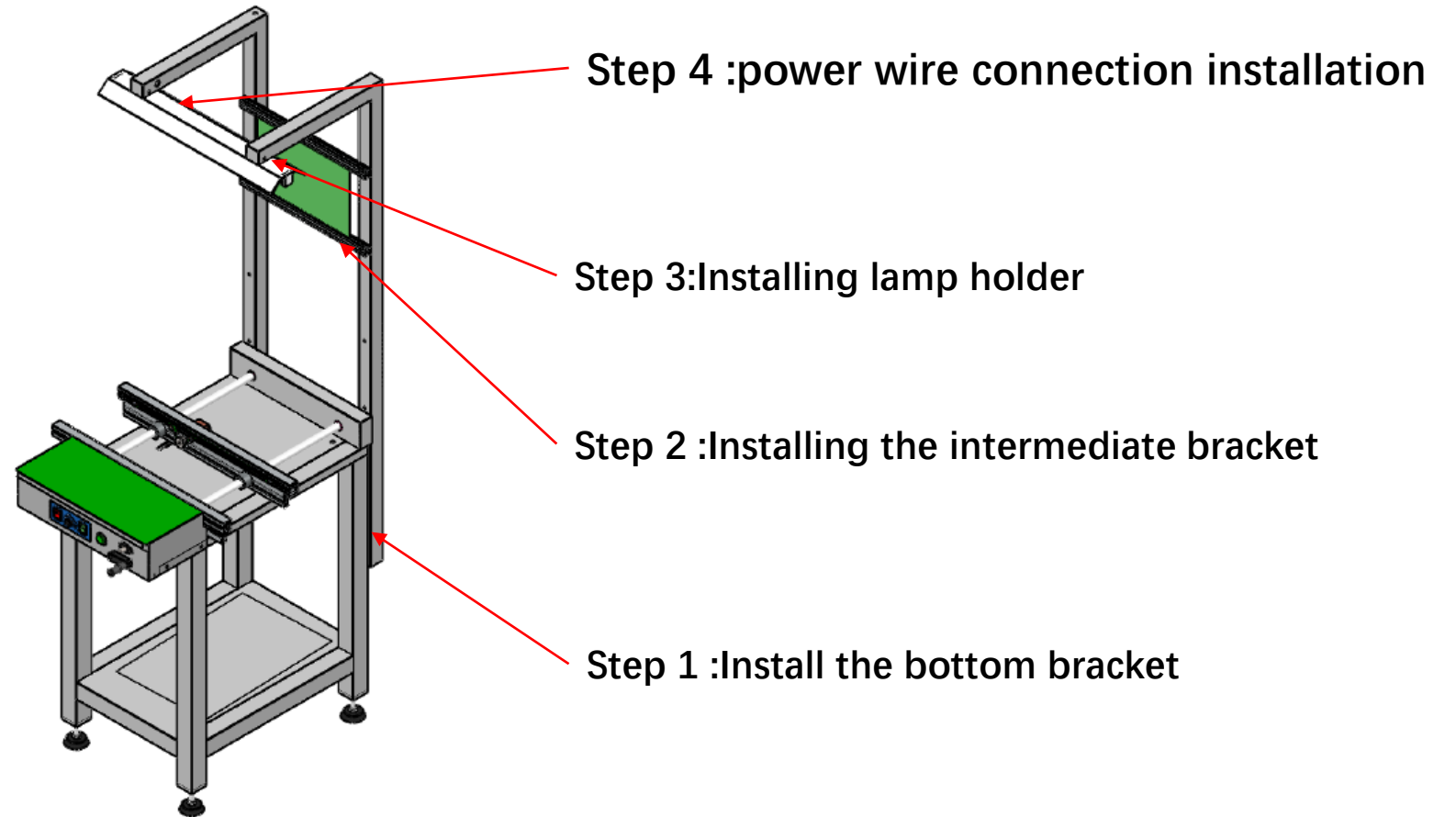

Detailed list of accessories

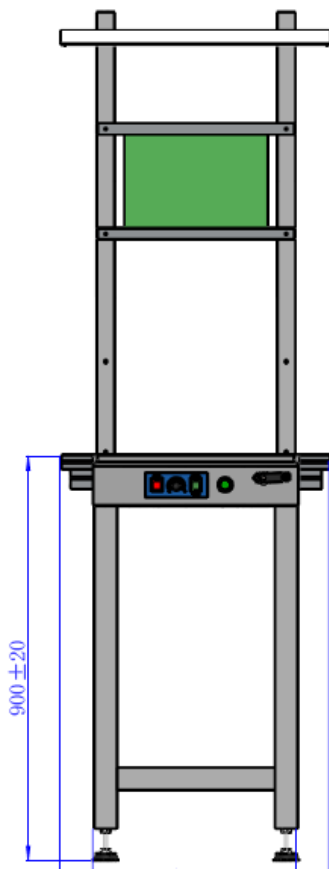
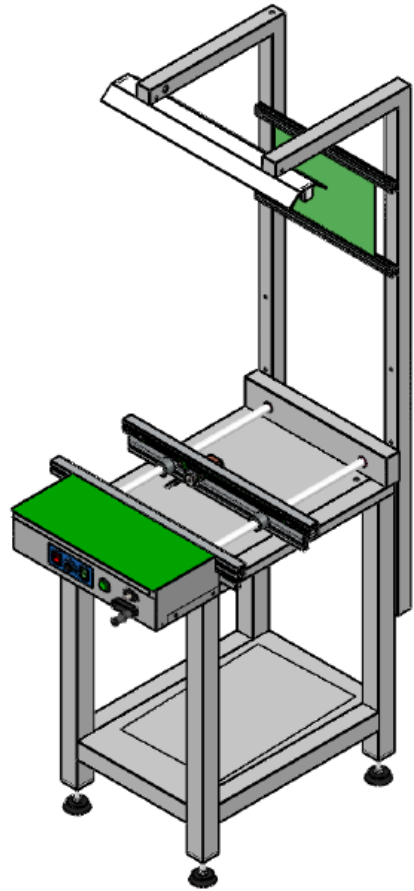

Item	Name	size	Quantity
1	1.A4 Hard rubber sleeve	A4	1
2	Energy saving lamp	1.2M	1
3	intermediate bracket	1.2M	2
4	Square light stand	1.2M	2
5	M6x65 screws	M6x65	4
6	M6x50 screws	M6x50	2
7	M4x20 screws	M4x20	4
8	M4x10 screws	M4x10	2
9	Light Power wire	1M	2
10	Top bracket	1.09M	1

Step 1 :Install the bottom bracket

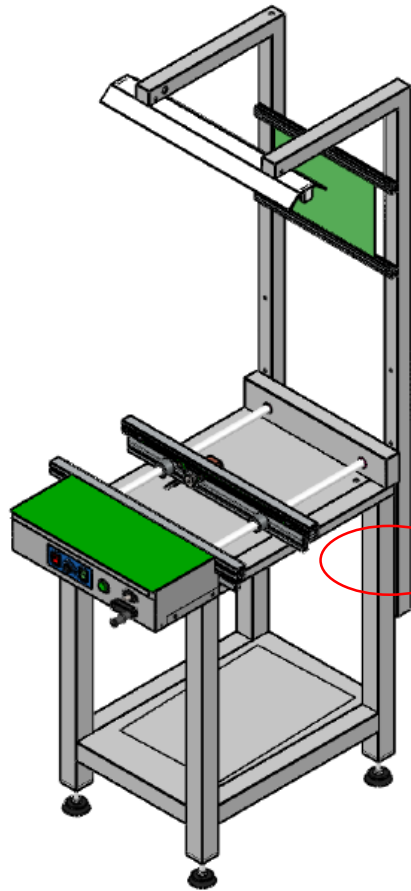

Secure the base bracket with 4 M6x65 screws
2 Square light stand

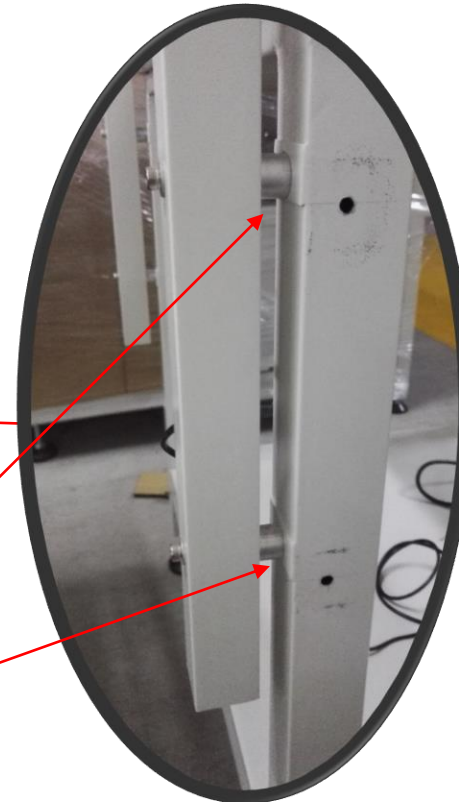

Step 2 :Installing the intermediate bracket

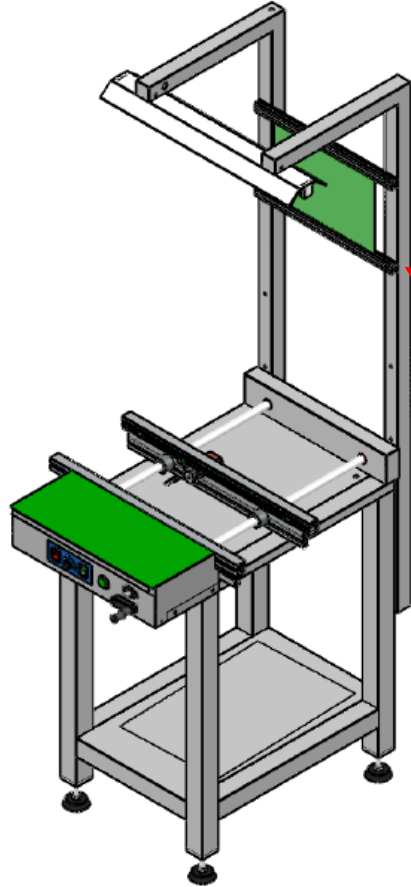

Secure the intermediate bracket with 4
M4x20 screws

Length 1.2m bracket

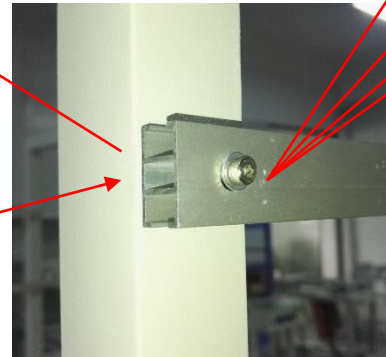

Step 3: Installing lamp holder

3.1 Use two M6X50 screws on the top to mount a 1.09 m bracket.

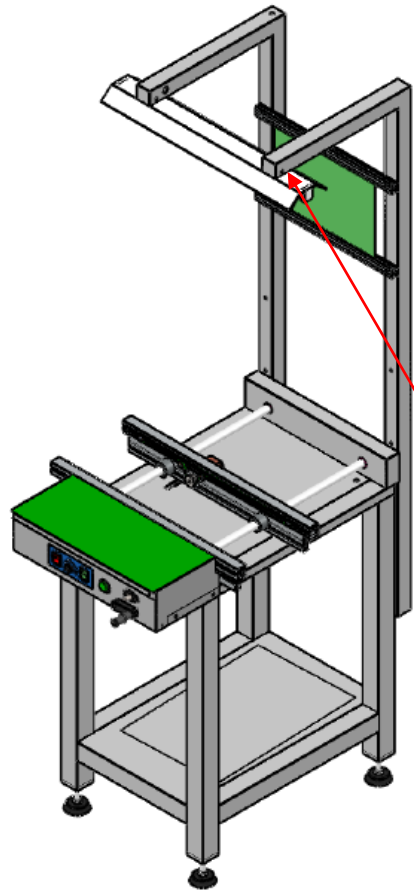

Top bracket

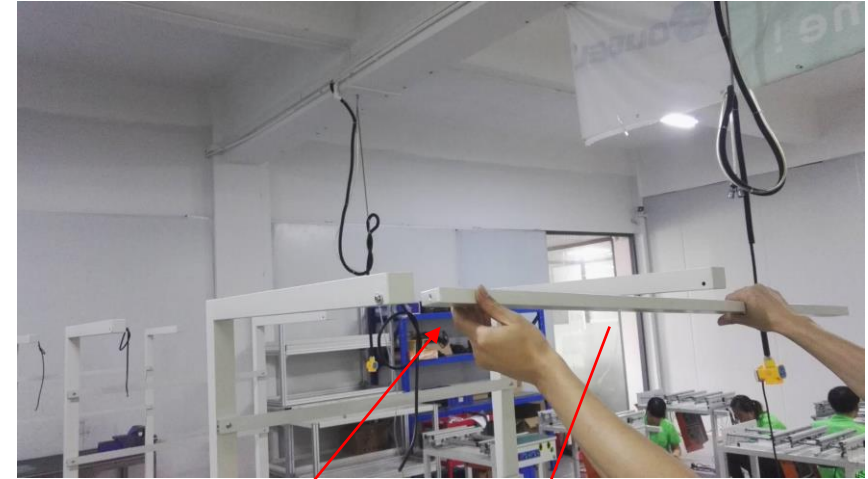

Length 1.09 m bracket



Step 3: Installing lamp holder

3.2 Lamp holder connector installation method

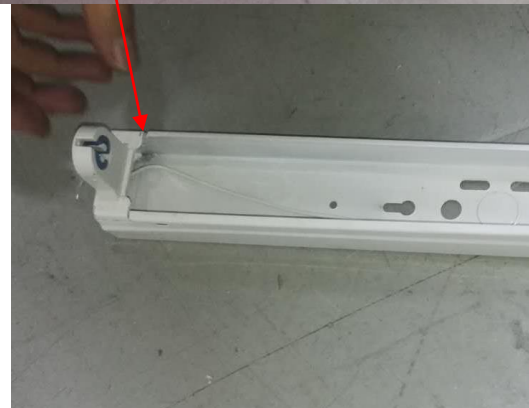
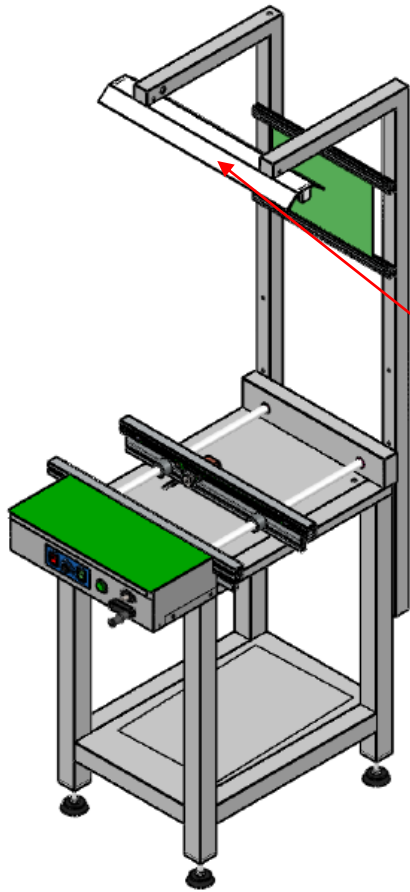

Step 3: Installing lamp holder

3.3 Fix the lamp holder to the bracket with M4X10 screws

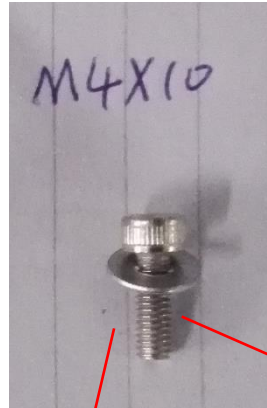
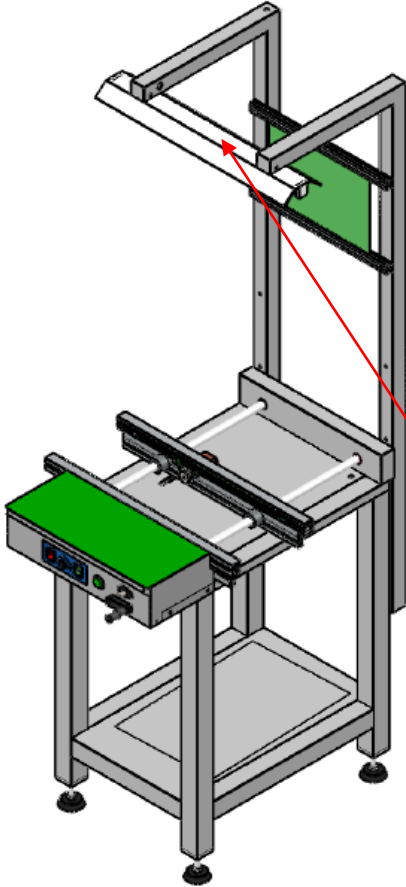

Step 3: Installing lamp holder

3.4 Light 110V power cable connection

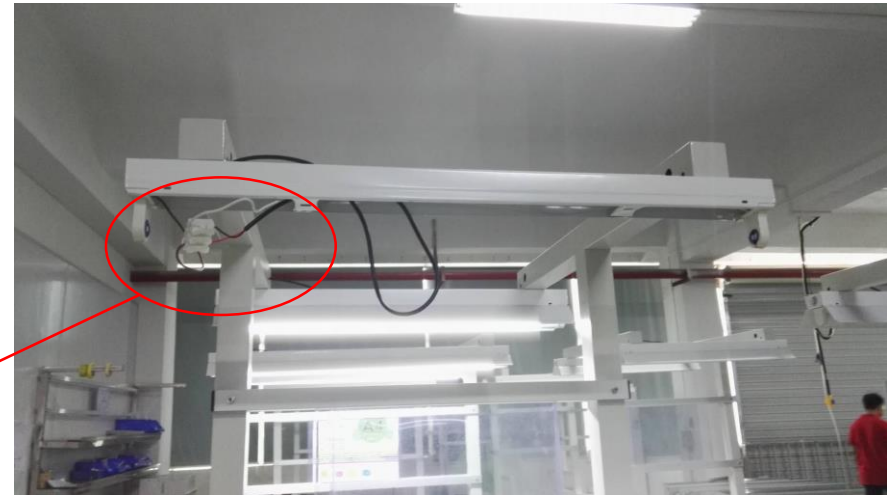
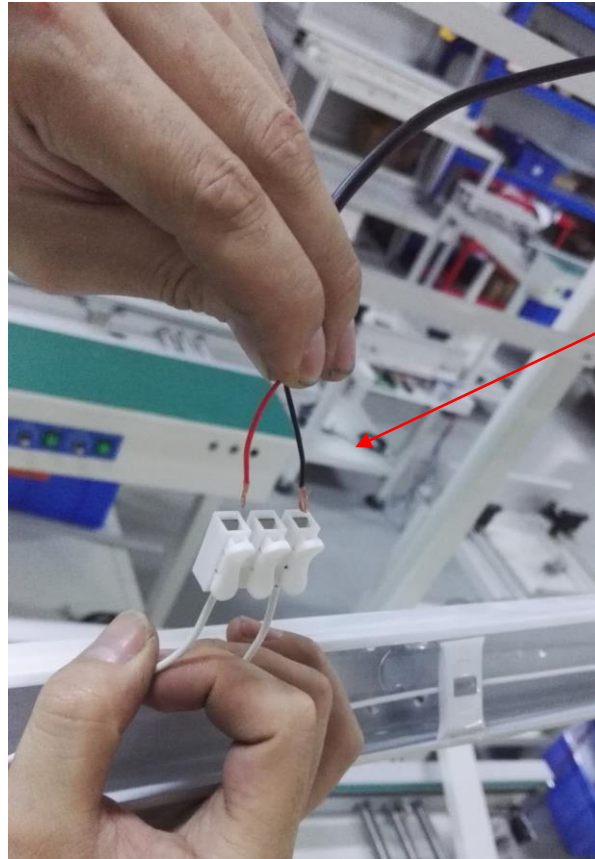
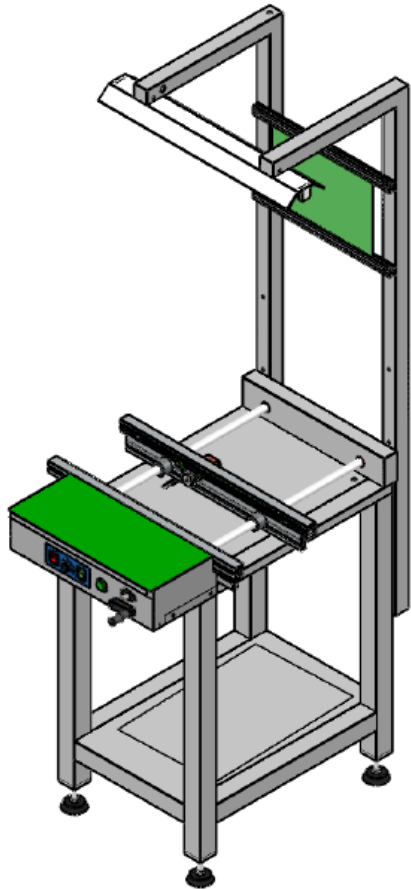

Step 3: Installing lamp holder

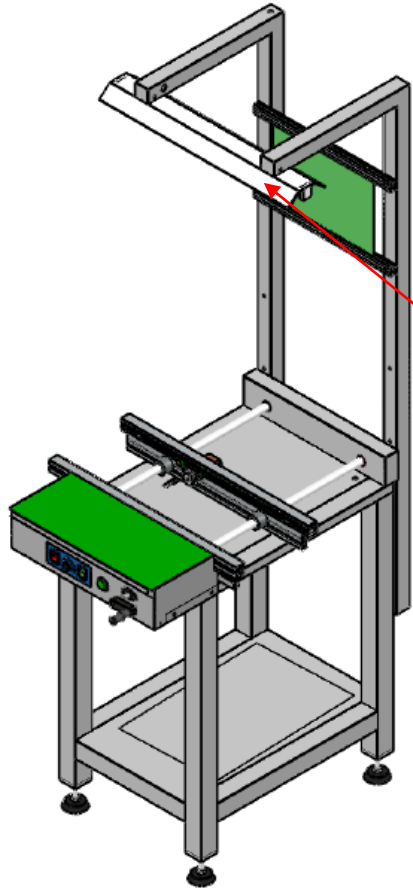

3.5 Lamp cover

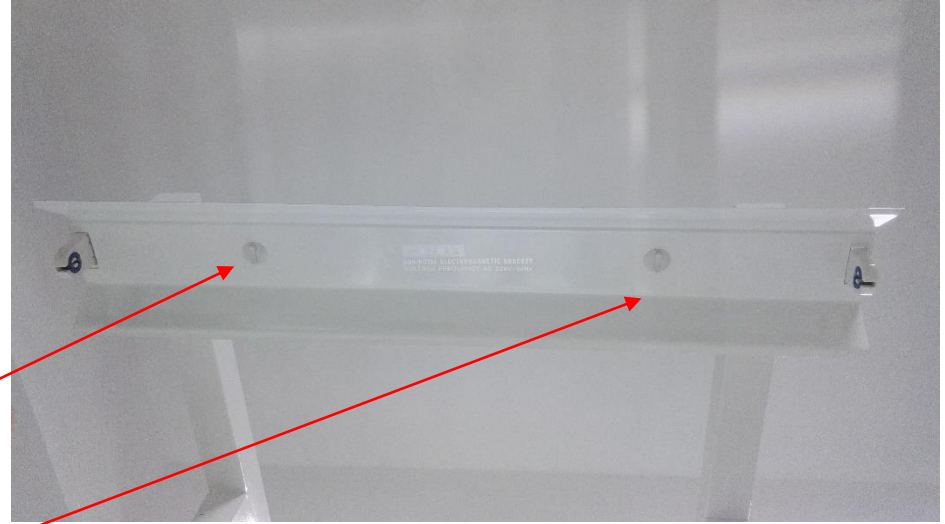
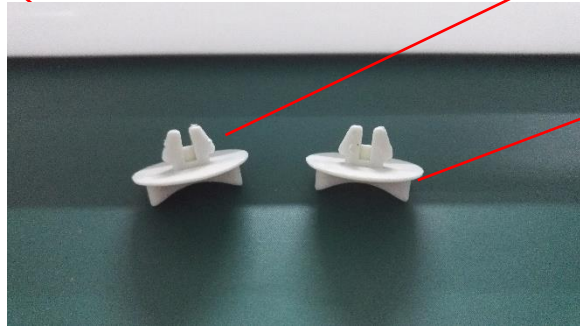

Step 4 :power wire connection installation

4.1, originally with a light, the machine has a terminal inside, you can directly connect the lamp holder power

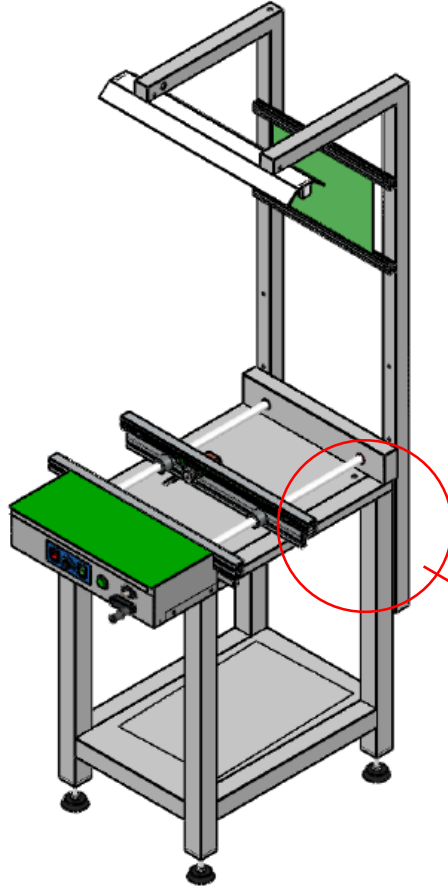

the machine has a terminal inside

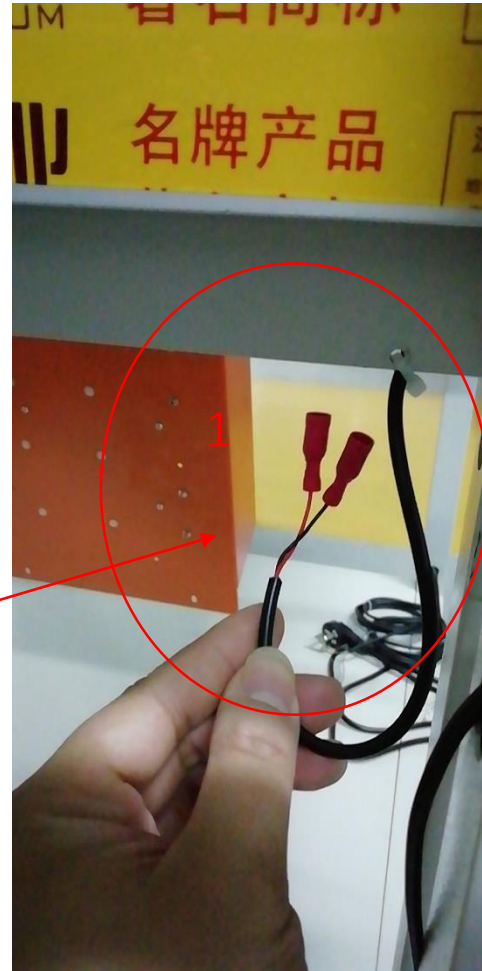

Step 4 : power wire connection installation

4.2, originally without a light, the new light stand, should be directly connected to the internal power supply terminal block

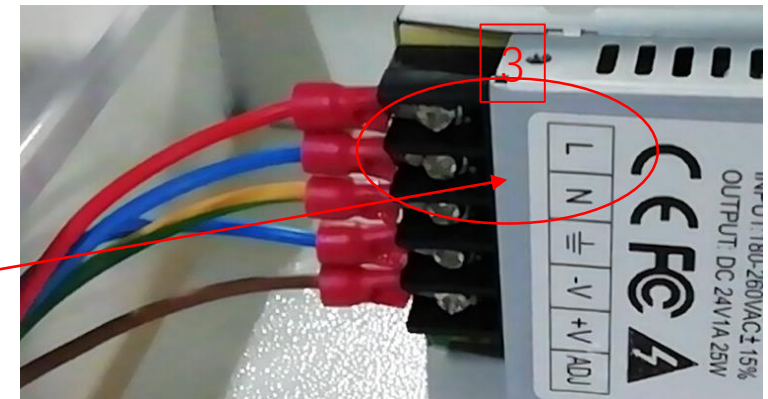
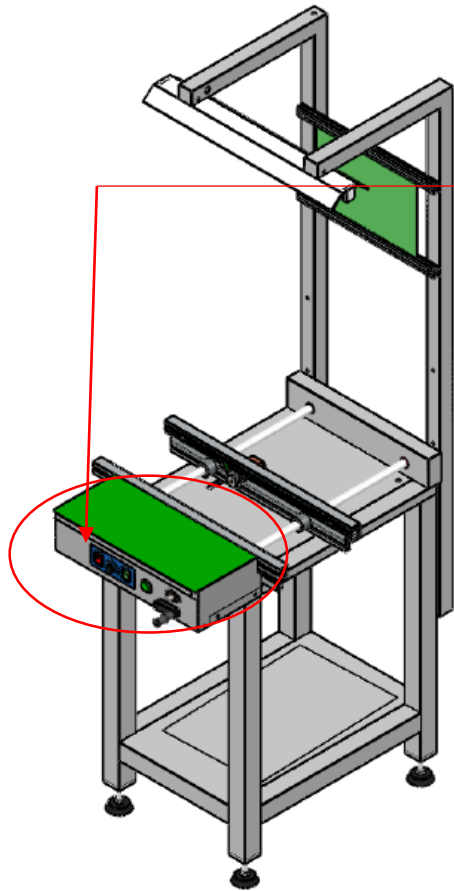

Use new wire connection

Red wire to L, black wire to N

- 1, Please visit : www.smthelp.com
- 2, Find us more: <https://www.facebook.com/autoinsertion>
- 3, Know more our team: <https://www.linkedin.com/in/ming-gan118/>
- 4, Welcome to our factory in Shenzhen China
- 5, See more video in Youtube: Auto+Insertion
- 4, Looking for more informations: ming@smthelp.com
5. Wechat/Whatsapp/skype: +86 18126316729