

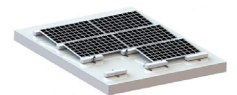

IPower the future
Lightening tomorrow

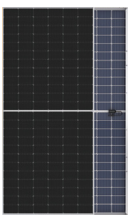

LITHIUM BATTERY SOLAR ENERGY STORAGE SYSTEM CATALOGUE 2024

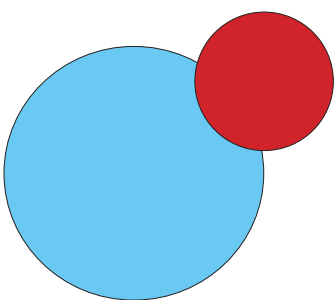

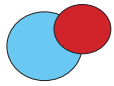

Shanghai Pvsys New Energy Co.,Ltd is the professional manufacturer of solar panel,solar storage system in the market for more than 13 years.

With our newest technology of Topcon,HJT, our customers can get higher efficiency with best performance through the lifespan of the solar panel.

Our solar storage system is with built in solar hybrid inverter,mppt controller and LifePO4 battery with BMS(Battery Management System), it can be used in No-power areas and it also helps our cusotmer to save their energy bill.We are offering the customization of our solar system based on different needs from our customers. We blieve that "a suitable one for you!"

We have acquired the certificates of CE,IEC61215-1-1:2021,IEC61730-1:2018,IEC 61730-2:2018 and Fire safety Class.

With high quality solar products and best service,we have customers from Italy,Germany,Sweden,Spain,England,Dub ai,South Africa,New Zeland,Australian,Japan,Indonesia.etc more than 50 countries and areas.

We always seem "Quality is our life", without good quality,we can not go any further. We blieve with our effort,we will make the world better.



700KW in Japan



300KW in Japan



13KW in Japan



6KW in Tahiti



14.76KW in Sweden



39.6KW-15.12kWh in Iraq

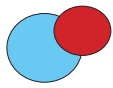

PERC MONOCRYSTALLINE SOLAR PANEL PVS-410W/420W-M10H



Introduction:

Redefined the high-efficiency module series by integrating 182mm silicon wafers with PERC cell technologies. Our panel combined creative technology effectively and extremely improved the module efficiency and power output.

Key Features:

- Less mismatch to get more power
- Less power loss by minimizing the shading impact
- Competitive low light performance
- 3 times EL test to ensure best quality
- Anti-PID
- Ideal choice for utility and commercial scale projects by reduced BoS and improved ROI
- Outstanding reliability proven by PVEL for stringent Environment condition: Sand, acid, salt and hail stones, 2400Pa wind load and 5400Pa snow load

Electrical Characteristics: STC: Irradiance 1000 W/m² module temperature 25 C AM=1.5

Module Type	PVS-410W-M10H	PVS-420W-M10H
Maximum Power (Pmp)	410W	420W
Open Circuit Voltage (Voc)	37.50V	37.90V
Short Circuit Current (Isc)	13.84A	13.97A
Maximum Power Voltage (Vmp)	31.30V	31.70V
Maximum Power Current (Imp)	13.10A	13.26A
Module Efficiency at STC(%)	22.37%	22.53%
Maximum System Voltage	1500VDC	
Maximum Series Fuse Rating	25A	
Power Tolerance	0~+3%	

Current-Voltage Characteristic (I-V Curve)

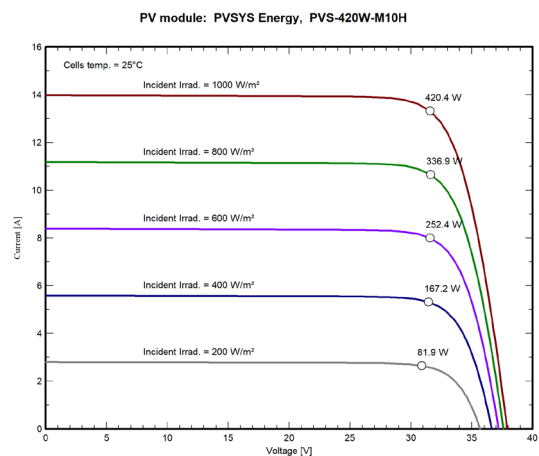

Mechanical Specifications:

External Dimensions	1722x1134x30mm
Solar Cells	Mono 108cells
Front Glass	3.2mm tempered glass
Frame	Anodized aluminum alloy
Junction Box	IP68, 3 diodes
Output Cables	4.0mm ²
Weight	22kg
Mechanical Load	Front side 5400Pa Rear side 2400Pa
Packing	36pcs/pallet, 936pcs/40HQ

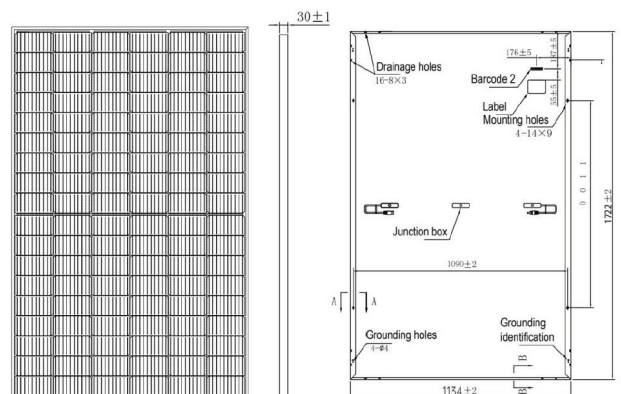

Product warranty:

15 years guarantee on product material and workmanship
 25 years guarantee on Liner power output

Quality Standard: IEC61215-1-1:2021, IEC61730-1 :2018, IEC61730-2:2018, Fire safety Class C

Temperature ratings (STC):

Temperature Coefficient of Isc	+0.040%/°C
Temperature Coefficient of Voc	-0.270%/°C
Temperature Coefficient of Pmax	-0.350%/°C

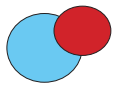

N-TYPE MONOCRYSTALLINE SOLAR PANEL PVS-450W/460W-M10HDT

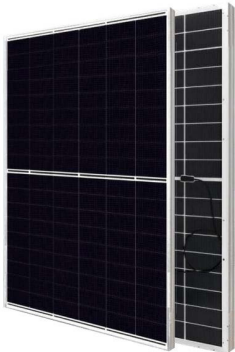

Introduction:

Redefined the high-efficiency module series by integrating 182mm silicon wafers with TOPCON N Type cell technologies. Our panel combined creative technology effectively and extremely improved the module efficiency and power output.

Key Features:

- Less mismatch to get more power
- Less power loss by minimizing the shading impact
- Competitive low light performance
- 3 times EL test to ensure best quality
- Anti-PID
- Ideal choice for utility and commercial scale projects by reduced BoS and improved ROI
- Outstanding reliability proven by PVEL for stringent Environment condition: Sand, acid, salt and hail stones, 2400Pa wind load and 5400Pa snow load

Electrical Characteristics: STC: Irradiance 1000 W/m² module temperature 25 C AM=1.5

Module Type	PVS-450W-M10HDT	PVS-460W-M10HDT
Maximum Power (Pmp)	450W	460W
Open Circuit Voltage (Voc)	39.58V	39.99V
Short Circuit Current (Isc)	14.35A	14.43A
Maximum Power Voltage (Vmp)	33.20V	33.60V
Maximum Power Current (Imp)	13.56A	13.69A
Module Efficiency at STC(%)	22.70%	23.10%
Maximum System Voltage	1500VDC	
Maximum Series Fuse Rating	25A	
Power Tolerance	0~+3%	

Current-Voltage Characteristic (I-V Curve)

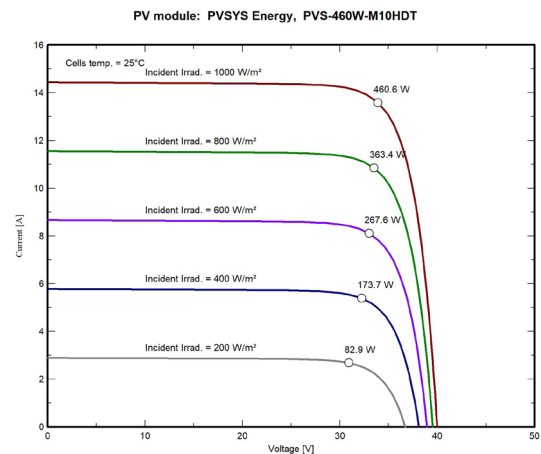

Mechanical Specifications:

External Dimensions	1802x1134x30 mm
Solar Cells	Mono 108cells
Front Glass	3.2mm tempered glass
Frame	Anodized aluminum alloy
Junction Box	IP68, 3 diodes
Output Cables	4.0mm ²
Weight	30.4kg
Mechanical Load	Front side 5400Pa Rear side 2400Pa
Packing	36pcs/pallet, 828pcs/40HQ

Back View

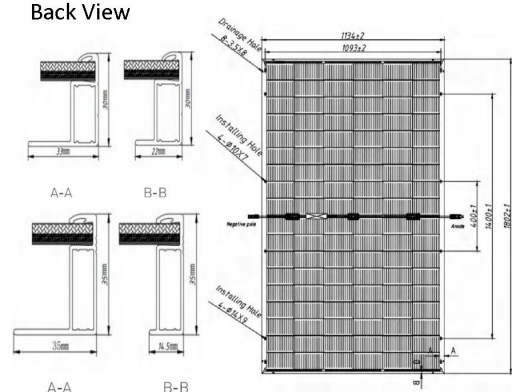

Temperature ratings (STC):

Temperature Coefficient of Isc	+0.046%/°C
Temperature Coefficient of Voc	-0.250%/°C
Temperature Coefficient of Pmax	-0.300%/°C

Product warranty:

15 years guarantee on product material and workmanship
 30 years guarantee on Liner power output

Quality Standard: IEC61215-1-1:2021, IEC61730-1 :2018, IEC61730-2:2018, Fire safety Class C

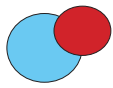

N-TYPE MONOCRYSTALLINE SOLAR PANEL PVS-575W/580W-M10HDT



Introduction:

Redefined the high-efficiency module series by integrating 182mm silicon wafers with N-type cell technologies. Our panel combined creative technology effectively and extremely improved the module efficiency and power output.

Key Features:

- Less mismatch to get more power
- Less power loss by minimizing the shading impact
- Competitive low light performance
- 3 times EL test to ensure best quality
- Anti-PID
- Ideal choice for utility and commercial scale projects by reduced BoS and improved ROI
- Outstanding reliability proven by PVEL for stringent Environment condition: Sand, acid, salt and hail stones, 2400Pa wind load and 5400Pa snow load

Electrical Characteristics: STC: Irradiance 1000 W/m² module temperature 25 C AM=1.5

Module Type	PVS-575W-M10HDT	PVS-580W-M10HDT
Maximum Power (Pmp)	575W	580W
Open Circuit Voltage (Voc)	51.27V	51.47V
Short Circuit Current (Isc)	14.31A	14.37A
Maximum Power Voltage (Vmp)	42.44V	42.59V
Maximum Power Current (Imp)	13.55A	13.62A
Module Efficiency at STC(%)	22.26%	22.45%
Maximum System Voltage	1500VDC	
Maximum Series Fuse Rating	30A	
Power Tolerance	0~+3%	

Current-Voltage Characteristic (I-V Curve)

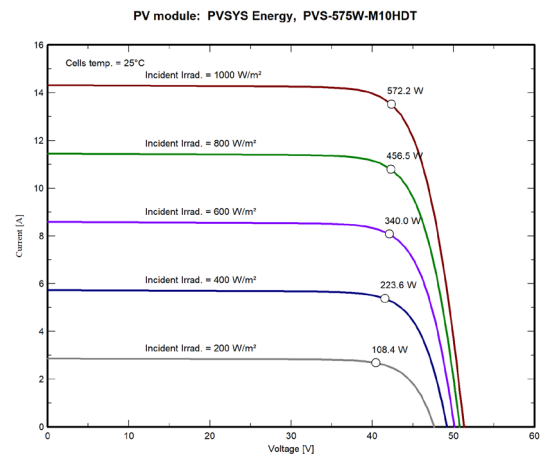

Mechanical Specifications:

External Dimensions	2278x1134x30 mm
Solar Cells	N-Type Mono 144cells(6*24)
Front Glass	3.2mm tempered glass
Frame	Anodized aluminum alloy
Junction Box	IP68, 3 diodes
Output Cables	4.0mm ² (300mm+/300mm-)
Weight	32kg
Mechanical Load	Front side 5400Pa Rear side 2400Pa
Packing	36pcs/pallet, 720pcs/40HQ

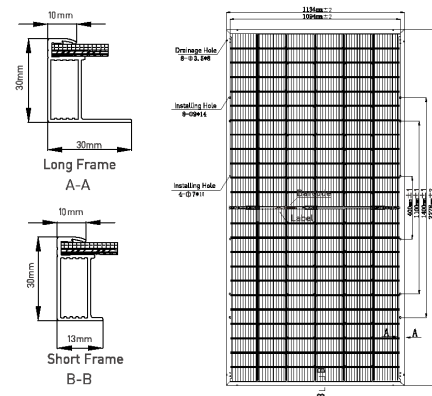

Product warranty:

15 years guarantee on product material and workmanship
 30 years guarantee on Liner power output

Quality Standard: IEC61215-1-1:2021, IEC61730-1 :2018, IEC61730-2:2018, Fire safety Class C

Temperature ratings (STC):

Temperature Coefficient of Isc	+0.046%/°C
Temperature Coefficient of Voc	-0.250%/°C
Temperature Coefficient of Pmax	-0.290%/°C

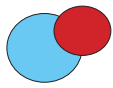

N-TYPE MONOCRYSTALLINE SOLAR PANEL PVS-600W/610W-M10HDT

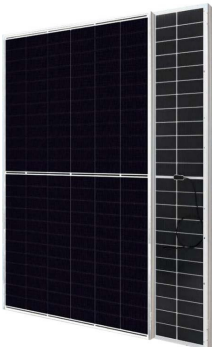

Introduction:

Redefined the high-efficiency module series by integrating 182mm silicon wafers with N-type cell technologies. Our panel combined creative technology effectively and extremely improved the module efficiency and power output.

Key Features:

- Less mismatch to get more power
- Less power loss by minimizing the shading impact
- Competitive low light performance
- 3 times EL test to ensure best quality
- Anti-PID
- Ideal choice for utility and commercial scale projects by reduced BoS and improved ROI
- Outstanding reliability proven by PVEL for stringent Environment condition: Sand, acid, salt and hail stones, 2400Pa wind load and 5400Pa snow load

Electrical Characteristics: STC: Irradiance 1000 W/m² module temperature 25 C AM=1.5

Module Type	PVS-600W-M10HDT	PVS-610W-M10HDT
Maximum Power (Pmp)	600W	610W
Open Circuit Voltage (Voc)	51.80V	52.20V
Short Circuit Current (Isc)	14.54A	14.66A
Maximum Power Voltage (Vmp)	44.00V	44.40V
Maximum Power Current (Imp)	13.64A	13.74A
Module Efficiency at STC(%)	22.22%	22.60%
Maximum System Voltage	1500VDC	
Maximum Series Fuse Rating	25A	
Power Tolerance	0~+3%	

Current-Voltage Characteristic (I-V Curve)

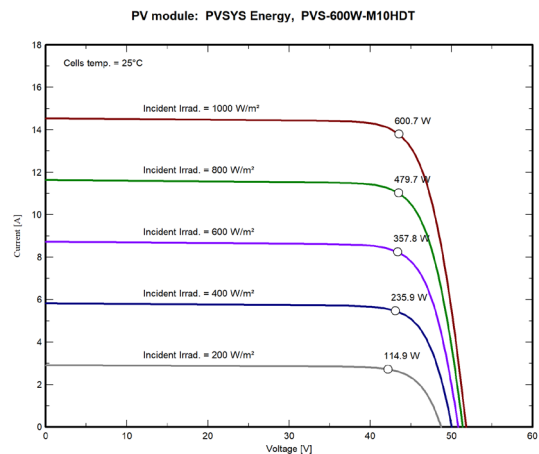

Mechanical Specifications:

External Dimensions	2382x1134x30 mm
Solar Cells	N-Type Mono 144cells(6*24)
Front Glass	3.2mm tempered glass
Frame	Anodized aluminum alloy
Junction Box	IP68, 3 diodes
Output Cables	4.0mm ² (300mm+/300mm-)
Weight	33.5kg
Mechanical Load	Front side 5400Pa Rear side 2400Pa
Packing	36pcs/pallet, 720pcs/40HQ

Back View

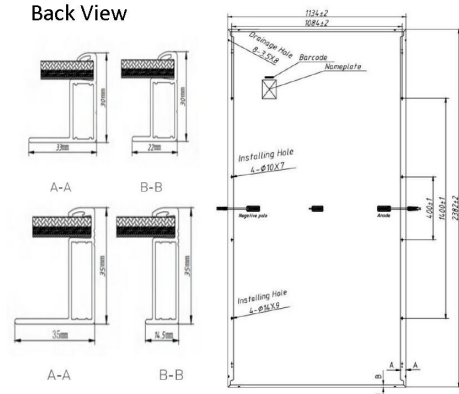

Temperature ratings (STC):

Temperature Coefficient of Isc	+0.046%/°C
Temperature Coefficient of Voc	-0.250%/°C
Temperature Coefficient of Pmax	-0.290%/°C

Product warranty:

15 years guarantee on product material and workmanship
 30 years guarantee on Liner power output

Quality Standard: IEC61215-1-1:2021, IEC61730-1 :2018, IEC61730-2:2018, Fire safety Class C

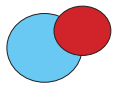

PERC MONOCRYSTALLINE SOLAR PANEL PVS-545W/550W-M10H



Introduction:

Redefined the high-efficiency module series by integrating 182mm silicon wafers with PERC cell technologies. Our panel combined creative technology effectively and extremely improved the module efficiency and power output.

Key Features:

- Less mismatch to get more power
- Less power loss by minimizing the shading impact
- Competitive low light performance
- 3 times EL test to ensure best quality
- Anti-PID
- Ideal choice for utility and commercial scale projects by reduced BoS and improved ROI
- Outstanding reliability proven by PVEL for stringent Environment condition: Sand, acid, salt and hail stones, 2400Pa wind load and 5400Pa snow load

Electrical Characteristics: STC: Irradiance 1000 W/m² module temperature 25 C AM=1.5

Module Type	PVS-545W-M10H	PVS-550W-M10H
Maximum Power (Pmp)	545W	550W
Open Circuit Voltage (Voc)	49.52V	49.62V
Short Circuit Current (Isc)	13.94A	14.03A
Maximum Power Voltage (Vmp)	40.80V	40.90V
Maximum Power Current (Imp)	13.36A	13.45A
Module Efficiency at STC(%)	21.2%	21.4%
Maximum System Voltage	1500VDC	
Maximum Series Fuse Rating	30A	
Power Tolerance	0~+3%	

Current-Voltage Characteristic (I-V Curve)

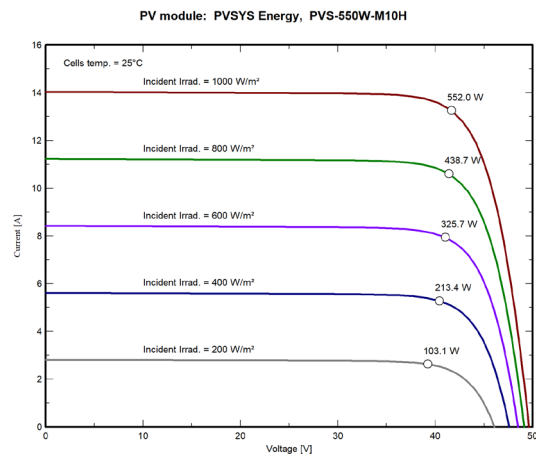

Mechanical Specifications:

External Dimensions	2279x1134x35 mm
Solar Cells	Mono 144cells(6*24)
Front Glass	3.2mm tempered glass
Frame	Anodized aluminum alloy
Junction Box	IP68, 3 diodes
Output Cables	4.0mm ²
Weight	29.4kg
Mechanical Load	Front side 5400Pa Rear side 2400Pa
Packing	31pcs/pallet, 620pcs/40HQ

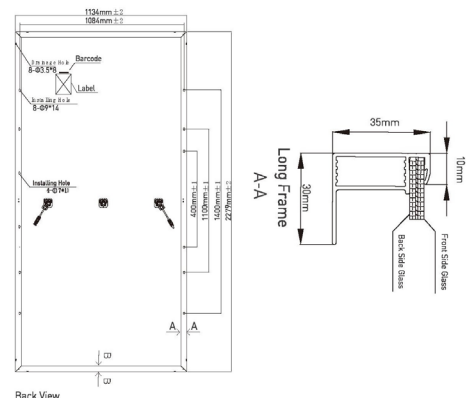

Temperature ratings (STC):

Temperature Coefficient of Isc	+0.048%/°C
Temperature Coefficient of Voc	-0.270%/°C
Temperature Coefficient of Pmax	-0.290%/°C

Product warranty:

15 years guarantee on product material and workmanship
 25 years guarantee on Liner power output

Quality Standard: IEC61215-1-1:2021, IEC61730-1 :2018, IEC61730-2:2018, Fire safety Class C



HPBC MONOCRYSTALLINE SOLAR PANEL PVS-590W/600W-M10HDT



Introduction:

Redefined the high-efficiency module series by integrating 182mm silicon wafers with HPBC cell technologies. Our panel combined creative technology effectively and extremely improved the module efficiency and power output.

Key Features:

- Less mismatch to get more power
- Less power loss by minimizing the shading impact
- Competitive low light performance
- 3 times EL test to ensure best quality
- Anti-PID
- Ideal choice for utility and commercial scale projects by reduced BoS and improved ROI
- Outstanding reliability proven by PVEL for stringent Environment condition: Sand, acid, salt and hail stones, 2400Pa wind load and 5400Pa snow load

Electrical Characteristics: STC: Irradiance 1000 W/m² module temperature 25 C AM=1.5

Module Type	PVS-590W-M10HDT	PVS-600W-M10HDT
Maximum Power (Pmp)	585W	600W
Open Circuit Voltage (Voc)	52.49V	52.79V
Short Circuit Current (Isc)	14.34A	14.47A
Maximum Power Voltage (Vmp)	44.38V	44.68V
Maximum Power Current (Imp)	13.30A	13.43A
Module Efficiency at STC(%)	22.8%	23.2%
Maximum System Voltage	1500VDC	
Maximum Series Fuse Rating	25A	
Power Tolerance	0~+3%	

Current-Voltage Characteristic (I-V Curve)

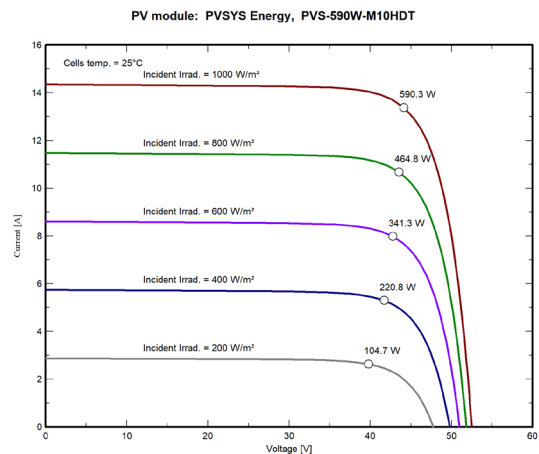

Mechanical Specifications:

External Dimensions	2278x1134x35 mm
Solar Cells	Mono 144cells(6*24)
Front Glass	3.2mm tempered glass
Frame	Anodized aluminum alloy
Junction Box	IP68, 3 diodes
Output Cables	4.0mm ²
Weight	27.5kg
Mechanical Load	Front side 5400Pa Rear side 2400Pa
Packing	31pcs/pallet, 620pcs/40HQ

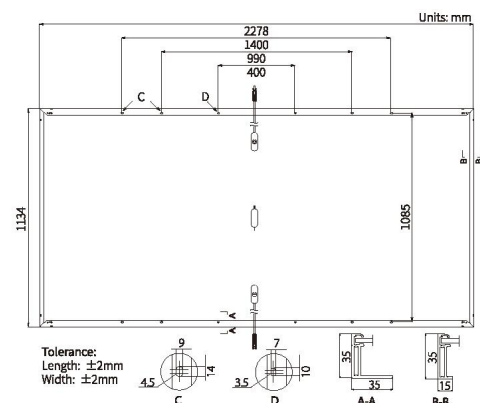

Temperature ratings (STC):

Temperature Coefficient of Isc	+0.050%/°C
Temperature Coefficient of Voc	-0.230%/°C
Temperature Coefficient of Pmax	-0.290%/°C

Product warranty:

15 years guarantee on product material and workmanship
 25 years guarantee on Liner power output

Quality Standard: IEC61215-1-1:2021, IEC61730-1 :2018, IEC61730-2:2018, Fire safety Class C

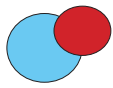

HJT MONOCRYSTALLINE SOLAR PANEL PVS-695W/700W-M12HDT

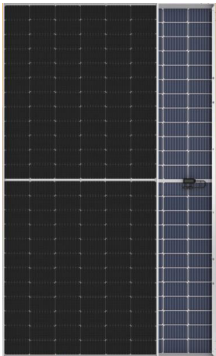

Introduction:

Redefined the high-efficiency module series by integrating 210mm silicon wafers with HJT cell technologies. Our panel combined creative technology effectively and extremely improved the module efficiency and power output.

Key Features:

- Less mismatch to get more power
- Less power loss by minimizing the shading impact
- Competitive low light performance
- 3 times EL test to ensure best quality
- Anti-PID
- Ideal choice for utility and commercial scale projects by reduced BoS and improved ROI
- Outstanding reliability proven by PVEL for stringent Environment condition: Sand, acid, salt and hail stones, 2400Pa wind load and 5400Pa snow load

Electrical Characteristics: STC: Irradiance 1000 W/m² module temperature 25 C AM=1.5

Module Type	PVS-695W-M12HDT	PVS-700W-M12HDT
Maximum Power (Pmp)	695W	700W
Open Circuit Voltage (Voc)	49.98V	50.13V
Short Circuit Current (Isc)	17.37A	17.43A
Maximum Power Voltage (Vmp)	41.95V	42.10V
Maximum Power Current (Imp)	16.57A	16.63A
Module Efficiency at STC(%)	22.37%	22.53%
Maximum System Voltage	1500VDC	
Maximum Series Fuse Rating	35A	
Power Tolerance	0~+3%	

Current-Voltage Characteristic (I-V Curve)

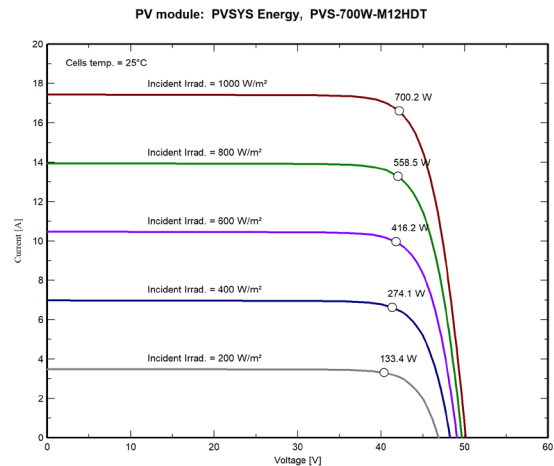

Mechanical Specifications:

External Dimensions	2385x1303x33 mm
Solar Cells	Mono 132cells
Front Glass	3.2mm tempered glass
Frame	Anodized aluminum alloy
Junction Box	IP68, 3 diodes
Output Cables	4.0mm ²
Weight	38.7kg
Mechanical Load	Front side 5400Pa Rear side 2400Pa
Packing	33pcs/pallet, 594pcs/40HQ

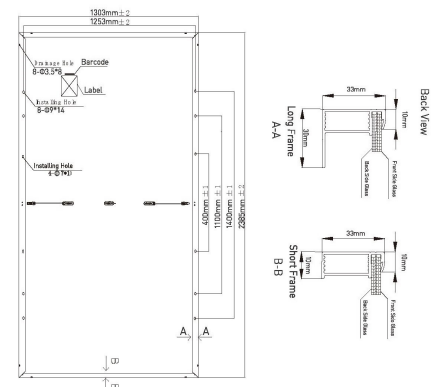

Temperature ratings (STC):

Temperature Coefficient of Isc	+0.040%/°C
Temperature Coefficient of Voc	-0.240%/°C
Temperature Coefficient of Pmax	-0.260%/°C

Product warranty:

15 years guarantee on product material and workmanship
 30 years guarantee on Liner power output

Quality Standard: IEC61215-1-1:2021, IEC61730-1 :2018, IEC61730-2:2018, Fire safety Class C

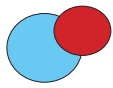

HJT MONOCRYSTALLINE SOLAR PANEL PVS-710W/720W-M12HDT

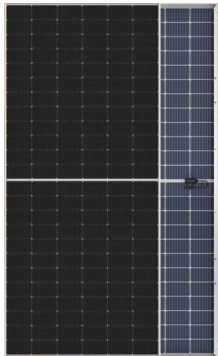

Introduction:

Redefined the high-efficiency module series by integrating 210mm silicon wafers with HJT cell technologies. Our panel combined creative technology effectively and extremely improved the module efficiency and power output.

Key Features:

- Less mismatch to get more power
- Less power loss by minimizing the shading impact
- Competitive low light performance
- 3 times EL test to ensure best quality
- Anti-PID
- Ideal choice for utility and commercial scale projects by reduced BoS and improved ROI
- Outstanding reliability proven by PVEL for stringent Environment condition: Sand, acid, salt and hail stones, 2400Pa wind load and 5400Pa snow load

Electrical Characteristics: STC: Irradiance 1000 W/m² module temperature 25 C AM=1.5

Module Type	PVS-710W-M12HDT	PVS-720W-M12HDT
Maximum Power (Pmp)	710W	720W
Open Circuit Voltage (Voc)	50.44V	50.95V
Short Circuit Current (Isc)	17.55A	17.66A
Maximum Power Voltage (Vmp)	42.40V	42.70V
Maximum Power Current (Imp)	16.75A	16.86A
Module Efficiency at STC(%)	22.85%	23.17%
Maximum System Voltage	1500VDC	
Maximum Series Fuse Rating	35A	
Power Tolerance	0~+3%	

Current-Voltage Characteristic (I-V Curve)

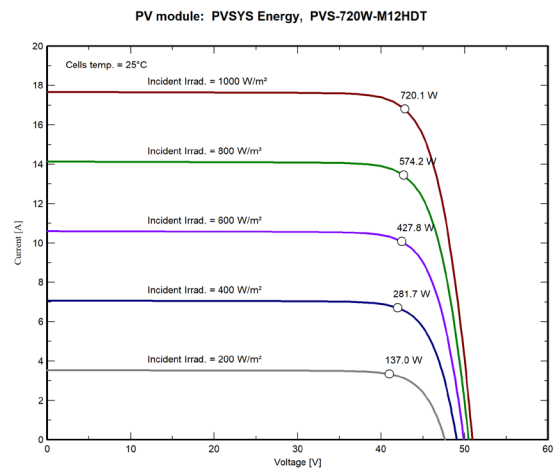

Mechanical Specifications:

External Dimensions	2385x1303x33 mm
Solar Cells	Mono 132cells
Front Glass	3.2mm tempered glass
Frame	Anodized aluminum alloy
Junction Box	IP68, 3 diodes
Output Cables	4.0mm ²
Weight	38.7kg
Mechanical Load	Front side 5400Pa Rear side 2400Pa
Packing	33pcs/pallet, 594pcs/40HQ

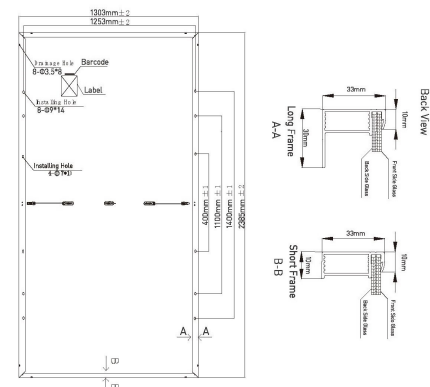

Temperature ratings (STC):

Temperature Coefficient of Isc	+0.040%/°C
Temperature Coefficient of Voc	-0.240%/°C
Temperature Coefficient of Pmax	-0.260%/°C

Product warranty:

15 years guarantee on product material and workmanship
 30 years guarantee on Liner power output

Quality Standard: IEC61215-1-1:2021, IEC61730-1 :2018, IEC61730-2:2018, Fire safety Class C

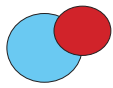

FLEXIBLE MONOCRYSTALLINE SOLAR PANEL PVS-350W-FM6

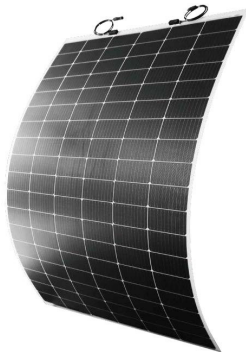

Introduction:

Redefined the high-efficiency module series by integrating 166mm silicon wafers with flexible cell technologies. Our panel combined creative technology effectively and extremely improved the module efficiency and power output.

Key Features:

- Light Weight, Frameless, Glass free
- Flexibility, Special manufacturing process and material provide bending ability
- Aesthetic Appearance, Half cell design, High Consistency
- Easy Installation, Light weight, easy for handling
- Customized, Provide customized service

Electrical Characteristics: STC:Irradiance 1000 W/m² module temperature 25 C AM=1.5

Module Type	PVS-350W-FM6
Maximum Power (Pmp)	350W
Open Circuit Voltage (Voc)	41.40V
Short Circuit Current (Isc)	10.70A
Maximum Power Voltage (Vmp)	34.70V
Maximum Power Current (Imp)	10.09A
Module Efficiency at STC(%)	18.16%
Maximum System Voltage	1000VDC
Maximum Series Fuse Rating	20A
Power Tolerance	0~+3%

Current-Voltage Characteristic (I-V Curve)

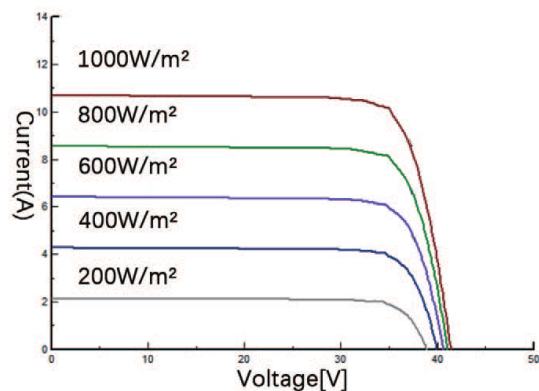

Mechanical Specifications:

External Dimensions	1785x1080x3 mm 1785x1080x18 mm(J-Box included)
Solar Cells	Mono 120cells
Cell Size	166x83 mm
Junction Box	IP67
Output Cables	4.0mm ²
Weight	6.1kg
Mechanical Load	Front side 5400Pa Rear side 2400Pa
Packing	70pcs/pallet 420pcs/20HQ,1820pcs/40HQ

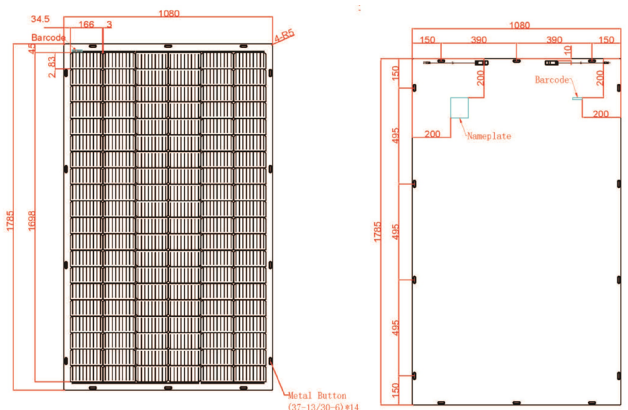

Product warranty:

12 years guarantee on product material and workmanship
 25 years guarantee on Liner power output

Temperature ratings (STC):

Temperature Coefficient of Isc	+0.020%/°C
Temperature Coefficient of Voc	-0.280%/°C
Temperature Coefficient of Pmax	-0.380%/°C

Quality Standard: IEC61215-1-1:2021, IEC61730-1 :2018, IEC61730-2:2018, Fire safety Class C

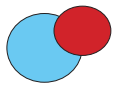

FLEXIBLE MONOCRYSTALLINE SOLAR PANEL PVS-400W/410W-FM10

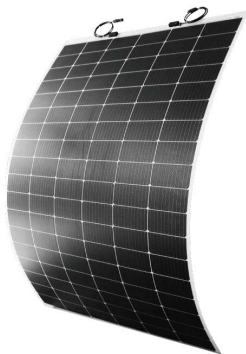

Introduction:

Redefined the high-efficiency module series by integrating 182mm silicon wafers with flexible cell technologies. Our panel combined creative technology effectively and extremely improved the module efficiency and power output.

Key Features:

- Light Weight, Frameless, Glass free
- Flexibility, Special manufacturing process and material provide bending ability
- Aesthetic Appearance, Half cell design, High Consistency
- Easy Installation, Light weight, easy for handling
- Customized, Provide customized service

Electrical Characteristics: STC: Irradiance 1000 W/m² module temperature 25 C AM=1.5

Module Type	PVS-400W-FM10	PVS-410W-FM10
Maximum Power (Pmp)	400W	410W
Open Circuit Voltage (Voc)	37.10V	37.30V
Short Circuit Current (Isc)	13.66A	13.90A
Maximum Power Voltage (Vmp)	30.70V	30.90V
Maximum Power Current (Imp)	13.03A	13.29A
Module Efficiency at STC(%)	20.21%	20.71%
Maximum System Voltage	1500VDC	
Maximum Series Fuse Rating	20A	
Power Tolerance	0~+3%	

Current-Voltage Characteristic (I-V Curve)

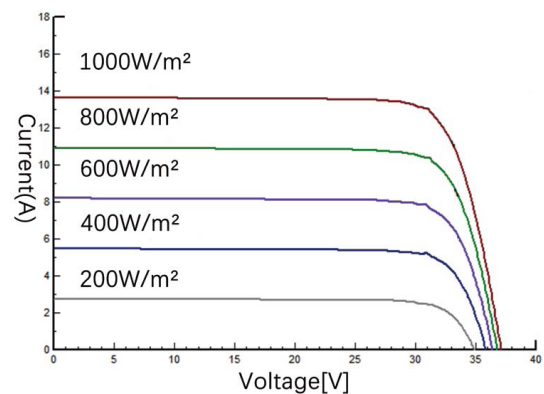

Mechanical Specifications:

External Dimensions	1735x1141x3 mm 1735x1141x18 mm(J-Box included)
Solar Cells	Mono 108cells
Cell Size	182x91 mm
Junction Box	IP67
Output Cables	4.0mm ²
Weight	6.3kg
Mechanical Load	Front side 5400Pa Rear side 2400Pa
Packing	70pcs/pallet 420pcs/20HQ, 1820pcs/40HQ

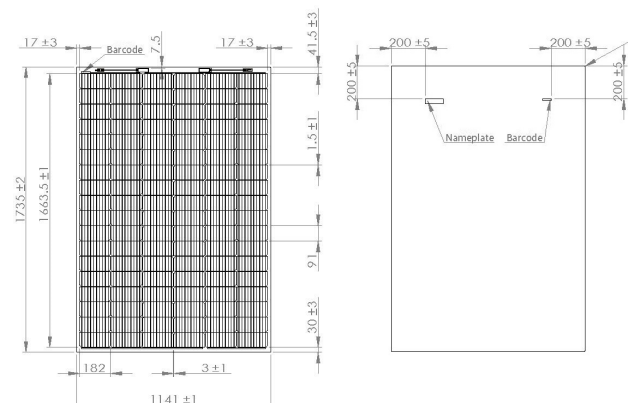

Product warranty:

12 years guarantee on product material and workmanship
 25 years guarantee on Liner power output

Temperature ratings (STC):

Temperature Coefficient of Isc	+0.020%/°C
Temperature Coefficient of Voc	-0.280%/°C
Temperature Coefficient of Pmax	-0.380%/°C

Quality Standard: IEC61215-1-1:2021, IEC61730-1 :2018, IEC61730-2:2018, Fire safety Class C

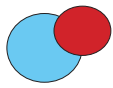

PERC MONOCRYSTALLINE SOLAR PANEL PVS-100W/120W-36M

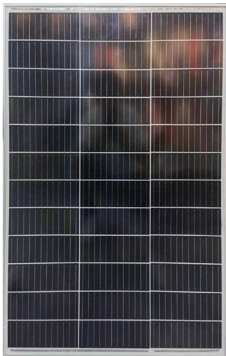

Introduction:

Redefined the high-efficiency module series by integrating 210mm silicon wafers with PERC cell technologies. Our panel combined creative technology effectively and extremely improved the module efficiency and power output.

Key Features:

- Less mismatch to get more power
- Less power loss by minimizing the shading impact
- Competitive low light performance
- 3 times EL test to ensure best quality
- Anti-PID
- Ideal choice for utility and commercial scale projects by reduced BoS and improved ROI
- Outstanding reliability proven by PVEL for stringent Environment condition: Sand, acid, salt and hail stones, 2400Pa wind load and 5400Pa snow load

Electrical Characteristics: STC: Irradiance 1000 W/m² module temperature 25 C AM=1.5

Module Type	PVS-100W-36M	PVS-105W-36M	PVS-110W-36M	PVS-115W-36M	PVS-120W-36M
Maximum Power (Pmp)	100W	105W	110W	115W	120W
Open Circuit Voltage (Voc)	23.14V	23.40V	23.66V	23.92V	24.18V
Short Circuit Current (Isc)	7.31A	7.60A	7.87A	8.13A	8.40A
Maximum Power Voltage (Vmp)	17.80V	18.00V	18.20V	18.4V	18.60V
Maximum Power Current (Imp)	5.62A	5.84A	6.05A	6.25A	6.46A
Module Efficiency at STC(%)	15.99%	16.78%	17.58%	18.38%	19.18%
Maximum System Voltage	1500VDC				
Maximum Series Fuse Rating	15A				
Power Tolerance	0~+3%				

Mechanical Specifications:

External Dimensions	920x680x30 mm
Solar Cells	210mm*70mm (36cells)
Front Glass	3.2mm tempered glass
Frame	Anodized aluminum alloy
Junction Box	IP65 with bypass diodes
Output Cables	2.5mm ² 900mm
Weight	8kg (Approximate)
Mechanical Load	Front side 5400Pa Rear side 2400Pa

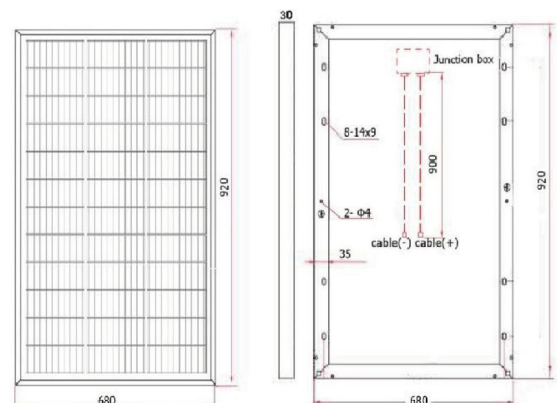

Temperature ratings (STC):

Temperature Coefficient of Isc	+0.050%/°C
Temperature Coefficient of Voc	-0.230%/°C
Temperature Coefficient of Pmax	-0.290%/°C

Product warranty:

15 years guarantee on product material and workmanship
 25 years guarantee on Liner power output

Quality Standard: IEC61215-1-1:2021, IEC61730-1 :2018, IEC61730-2:2018, Fire safety Class C

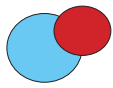

PERC MONOCRYSTALLINE SOLAR PANEL PVS-170W/190W-39M

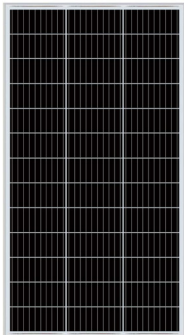

Introduction:

Redefined the high-efficiency module series by integrating 210mm silicon wafers with PERC cell technologies. Our panel combined creative technology effectively and extremely improved the module efficiency and power output.

Key Features:

- Less mismatch to get more power
- Less power loss by minimizing the shading impact
- Competitive low light performance
- 3 times EL test to ensure best quality
- Anti-PID
- Ideal choice for utility and commercial scale projects by reduced BoS and improved ROI
- Outstanding reliability proven by PVEL for stringent Environment condition: Sand, acid, salt and hail stones, 2400Pa wind load and 5400Pa snow load

Electrical Characteristics: STC: Irradiance 1000 W/m² module temperature 25 C AM=1.5

Module Type	PVS-170W-39M	PVS-175W-39M	PVS-180W-39M	PVS-185W-39M	PVS-190W-39M
Maximum Power (Pmp)	170W	175W	180W	185W	190W
Open Circuit Voltage (Voc)	27.89V	28.15V	28.40V	28.65V	28.90V
Short Circuit Current (Isc)	10.31A	10.52A	10.73A	10.92A	11.12A
Maximum Power Voltage (Vmp)	21.45V	21.65V	21.84V	22.04V	22.23V
Maximum Power Current (Imp)	7.93A	8.09A	8.25A	8.40A	8.55A
Cell Efficiency at STC(%)	19.80%	20.40%	21.00%	21.50%	22.10%
Maximum System Voltage	1500VDC				
Maximum Series Fuse Rating	15A				
Power Tolerance	0~+3%				

Mechanical Specifications:

External Dimensions	1480x680x35 mm
Solar Cells	210mm*105mm (39cells)
Front Glass	3.2mm tempered glass
Frame	Anodized aluminum alloy
Junction Box	IP67 with bypass diodes
Output Cables	2.5mm ² 900mm
Weight	12kg (Approximate)
Mechanical Load	Front side 5400Pa Rear side 2400Pa

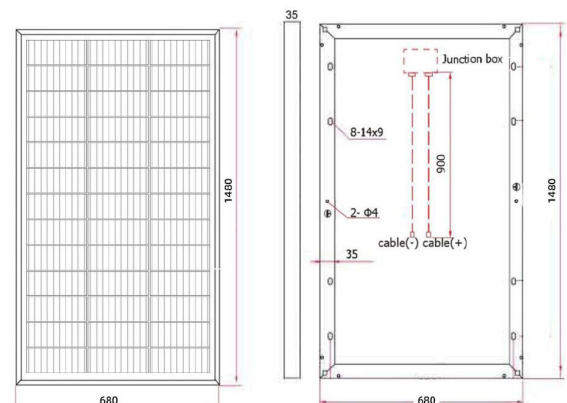

Temperature ratings (STC):

Temperature Coefficient of Isc	+0.050%/°C
Temperature Coefficient of Voc	-0.230%/°C
Temperature Coefficient of Pmax	-0.290%/°C

Product warranty:

15 years guarantee on product material and workmanship
 25 years guarantee on Liner power output

Quality Standard: IEC61215-1-1:2021, IEC61730-1 :2018, IEC61730-2:2018, Fire safety Class C

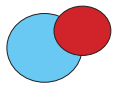

PERC MONOCRYSTALLINE SOLAR PANEL PVS-210W/250W-64M



Introduction:

Redefined the high-efficiency module series by integrating 182mm silicon wafers with PERC cell technologies. Our panel combined creative technology effectively and extremely improved the module efficiency and power output.

Key Features:

- Less mismatch to get more power
- Less power loss by minimizing the shading impact
- Competitive low light performance
- 3 times EL test to ensure best quality
- Anti-PID
- Ideal choice for utility and commercial scale projects by reduced BoS and improved ROI
- Outstanding reliability proven by PVEL for stringent Environment condition: Sand, acid, salt and hail stones, 2400Pa wind load and 5400Pa snow load

Electrical Characteristics: STC: Irradiance 1000 W/m² module temperature 25 C AM=1.5

Module Type	PVS-210W-64M	PVS-220W-64M	PVS-230W-64M	PVS-240W-64M	PVS-250W-64M
Maximum Power (Pmp)	210W	220W	230W	240W	250W
Open Circuit Voltage (Voc)	42.47V	43.00V	43.58V	43.97V	44.80V
Short Circuit Current (Isc)	6.46A	6.55A	6.64A	6.73A	6.82A
Maximum Power Voltage (Vmp)	37.23V	38.02V	38.53V	39.04V	39.55V
Maximum Power Current (Imp)	5.65A	5.79A	6.01A	6.15A	6.32A
Cell Efficiency at STC(%)	20.10%	21.00%	21.90%	22.80%	23.70%
Maximum System Voltage	1500VDC				
Maximum Series Fuse Rating	25A				
Power Tolerance	0~+3%				

Mechanical Specifications:

External Dimensions	1580x808x35 mm
Solar Cells	182mm*91mm (64cells)
Front Glass	3.2mm tempered glass
Frame	Anodized aluminum alloy
Junction Box	IP67 with bypass diodes
Output Cables	4mm ² 900mm
Weight	16.5kg (Approximate)
Mechanical Load	Front side 5400Pa Rear side 2400Pa

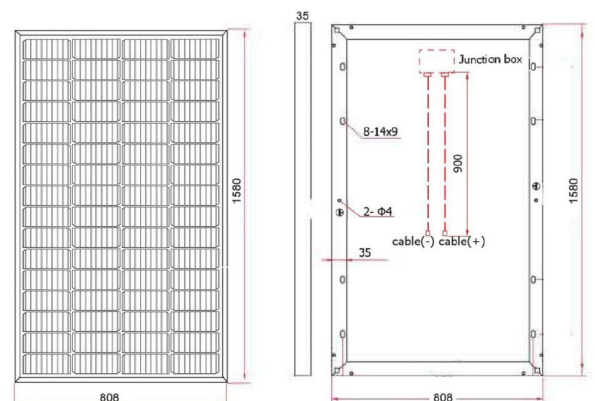

Temperature ratings (STC):

Temperature Coefficient of Isc	+0.050%/°C
Temperature Coefficient of Voc	-0.230%/°C
Temperature Coefficient of Pmax	-0.290%/°C

Product warranty:

15 years guarantee on product material and workmanship
 25 years guarantee on Liner power output

Quality Standard: IEC61215-1-1:2021, IEC61730-1 :2018, IEC61730-2:2018, Fire safety Class C



PERC MONOCRYSTALLINE SOLAR PANEL PVS-230W/270W-32M

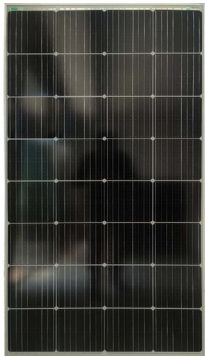

Introduction:

Redefined the high-efficiency module series by integrating 182mm silicon wafers with PERC cell technologies. Our panel combined creative technology effectively and extremely improved the module efficiency and power output.

Key Features:

- Less mismatch to get more power
- Less power loss by minimizing the shading impact
- Competitive low light performance
- 3 times EL test to ensure best quality
- Anti-PID
- Ideal choice for utility and commercial scale projects by reduced BoS and improved ROI
- Outstanding reliability proven by PVEL for stringent Environment condition: Sand, acid, salt and hail stones, 2400Pa wind load and 5400Pa snow load

Electrical Characteristics: STC: Irradiance 1000 W/m² module temperature 25 C AM=1.5

Module Type	PVS-230W-32M	PVS-240W-32M	PVS-250W-32M	PVS-260W-32M	PVS-270W-32M
Maximum Power (Pmp)	230W	240W	250W	260W	270W
Open Circuit Voltage (Voc)	24.60V	25.01V	25.43V	25.85V	26.26V
Short Circuit Current (Isc)	15.81A	16.22A	16.62A	17.00A	17.38A
Maximum Power Voltage (Vmp)	18.92V	19.24V	19.56V	19.88V	20.20V
Maximum Power Current (Imp)	12.16A	12.48A	12.79A	13.08A	13.37A
Cell Efficiency at STC(%)	21.70%	22.64%	23.59%	24.53%	25.47%
Maximum System Voltage	1500VDC				
Maximum Series Fuse Rating	20A				
Power Tolerance	0~+3%				

Mechanical Specifications:

External Dimensions	1530x770x35 mm
Solar Cells	182mm*182mm (32cells)
Front Glass	3.2mm tempered glass
Frame	Anodized aluminum alloy
Junction Box	IP67 with bypass diodes
Output Cables	4mm ² 900mm
Weight	15kg (Approximate)
Mechanical Load	Front side 5400Pa Rear side 2400Pa

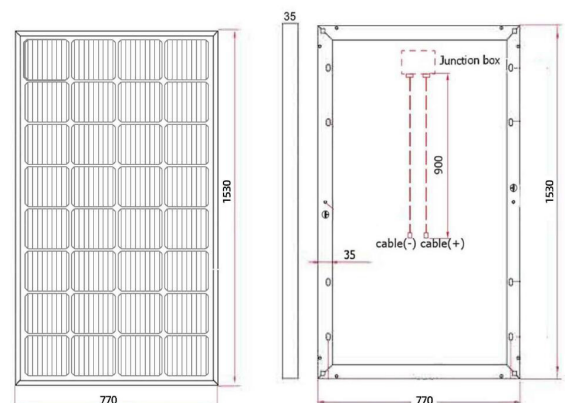

Temperature ratings (STC):

Temperature Coefficient of Isc	+0.050%/°C
Temperature Coefficient of Voc	-0.230%/°C
Temperature Coefficient of Pmax	-0.290%/°C

Product warranty:

15 years guarantee on product material and workmanship
 25 years guarantee on Liner power output

Quality Standard: IEC61215-1-1:2021, IEC61730-1 :2018, IEC61730-2:2018, Fire safety Class C

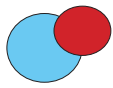

PERC MONOCRYSTALLINE SOLAR PANEL PVS-310W/330W-60M

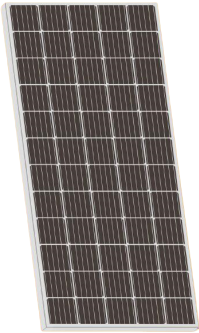

Introduction:

Redefined the high-efficiency module series by integrating 182mm silicon wafers with PERC cell technologies. Our panel combined creative technology effectively and extremely improved the module efficiency and power output.

Key Features:

- Less mismatch to get more power
- Less power loss by minimizing the shading impact
- Competitive low light performance
- 3 times EL test to ensure best quality
- Anti-PID
- Ideal choice for utility and commercial scale projects by reduced BoS and improved ROI
- Outstanding reliability proven by PVEL for stringent Environment condition: Sand, acid, salt and hail stones, 2400Pa wind load and 5400Pa snow load

Electrical Characteristics: STC: Irradiance 1000 W/m² module temperature 25 C AM=1.5

Module Type	PVS-310W-60M	PVS-315W-60M	PVS-320W-60M	PVS-325W-60M	PVS-330W-60M
Maximum Power (Pmp)	310W	315W	320W	325W	330W
Open Circuit Voltage (Voc)	43.36V	43.50V	43.74V	43.92V	44.20V
Short Circuit Current (Isc)	9.26A	9.39A	9.48A	9.59A	9.70A
Maximum Power Voltage (Vmp)	36.13V	36.25V	36.45V	36.60V	36.83V
Maximum Power Current (Imp)	8.58A	8.69A	8.78A	8.88A	8.96A
Cell Efficiency at STC(%)	21.90%	22.30%	22.60%	23.00%	23.30%
Maximum System Voltage	1500VDC				
Maximum Series Fuse Rating	20A				
Power Tolerance	0~+3%				

Mechanical Specifications:

External Dimensions	1640x992x35 mm
Solar Cells	182mm*130mm (60cells)
Front Glass	3.2mm tempered glass
Frame	Anodized aluminum alloy
Junction Box	IP68 with 3 bypass diodes
Output Cables	4mm ² 900mm
Weight	18kg (Approximate)
Mechanical Load	Front side 5400Pa Rear side 2400Pa

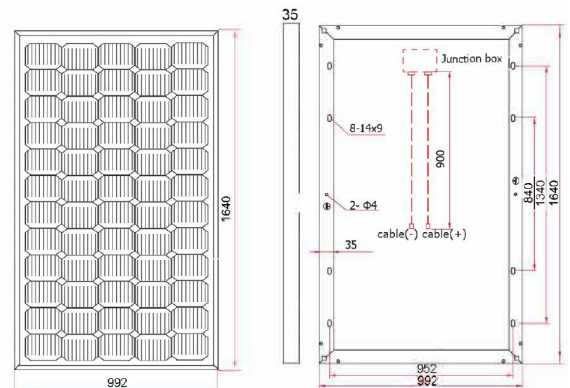

Temperature ratings (STC):

Temperature Coefficient of Isc	+0.050%/°C
Temperature Coefficient of Voc	-0.230%/°C
Temperature Coefficient of Pmax	-0.290%/°C

Product warranty:

15 years guarantee on product material and workmanship
25 years guarantee on Liner power output

Quality Standard: IEC61215-1-1:2021, IEC61730-1 :2018, IEC61730-2:2018, Fire safety Class C

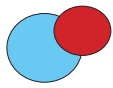

PERC MONOCRYSTALLINE SOLAR PANEL PVS-360W/380W-70M

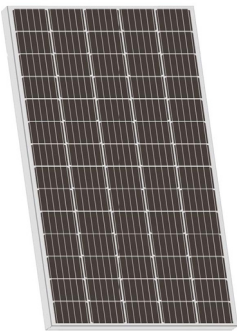

Introduction:

Redefined the high-efficiency module series by integrating 182mm silicon wafers with PERC cell technologies. Our panel combined creative technology effectively and extremely improved the module efficiency and power output.

Key Features:

- Less mismatch to get more power
- Less power loss by minimizing the shading impact
- Competitive low light performance
- 3 times EL test to ensure best quality
- Anti-PID
- Ideal choice for utility and commercial scale projects by reduced BoS and improved ROI
- Outstanding reliability proven by PVEL for stringent Environment condition: Sand, acid, salt and hail stones, 2400Pa wind load and 5400Pa snow load

Electrical Characteristics: STC: Irradiance 1000 W/m² module temperature 25 C AM=1.5

Module Type	PVS-360W-70M	PVS-365W-70M	PVS-370W-70M	PVS-375W-70M	PVS-380W-70M
Maximum Power (Pmp)	360W	365W	370W	375W	380W
Open Circuit Voltage (Voc)	50.35V	50.69V	50.92V	51.02V	51.12V
Short Circuit Current (Isc)	9.27A	9.33A	9.42A	9.53A	9.64A
Maximum Power Voltage (Vmp)	41.96V	42.25V	42.43V	42.52V	42.60V
Maximum Power Current (Imp)	8.58A	8.64A	8.73A	8.82A	8.93A
Cell Efficiency at STC(%)	21.90%	22.10%	22.40%	22.80%	23.10%
Maximum System Voltage	1500VDC				
Maximum Series Fuse Rating	20A				
Power Tolerance	0~+3%				

Mechanical Specifications:

External Dimensions	1956x992x35 mm
Solar Cells	182mm*130mm (70cells)
Front Glass	3.2mm tempered glass
Frame	Anodized aluminum alloy
Junction Box	IP68 with 3 bypass diodes
Output Cables	4mm ² 900mm
Weight	22kg (Approximate)
Mechanical Load	Front side 5400Pa Rear side 2400Pa

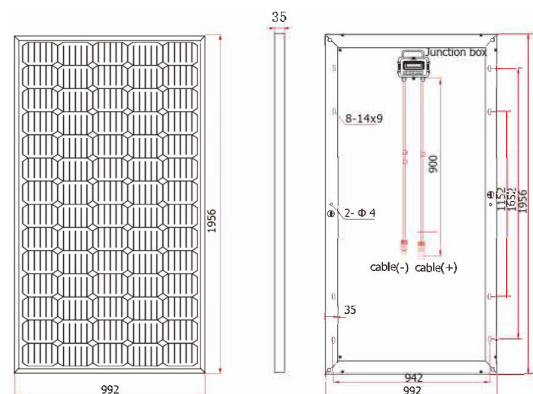

Temperature ratings (STC):

Temperature Coefficient of Isc	+0.050%/°C
Temperature Coefficient of Voc	-0.230%/°C
Temperature Coefficient of Pmax	-0.290%/°C

Product warranty:

15 years guarantee on product material and workmanship
 25 years guarantee on Liner power output

Quality Standard: IEC61215-1-1:2021, IEC61730-1 :2018, IEC61730-2:2018, Fire safety Class C

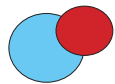

Japan 700KW



Japan 300KW



Japan 224KW



Japan 76KW



Japan 13KW



Japan 100KW



Japan 250KW



Italy 900KW



Tahiti 6KW



New Zealand 10KW



Sweden 14.76KW



Sweden 15.58KW



Sweden 15.99KW



Sweden 85.28KW



Iraq 39.6KW-15.12kWh



Indonesia 5KW-10.24kWh

SHANGAI PVSYS NEW ENERGY CO.,LTD
Add:3rd floor,No 1559 East Zhuan Xing Road,Shanghai,China.
Telephone: +86 17821615616
Email:sales@pv-system.net

PVSYS ENERGY GROUP LIMITED
Add: RM22 2/F Fu Tao Building No.98 Argyle Street Kowloon,HONG KONG
Telephone: +86 17821615616
Email:sales@pv-system.net

