

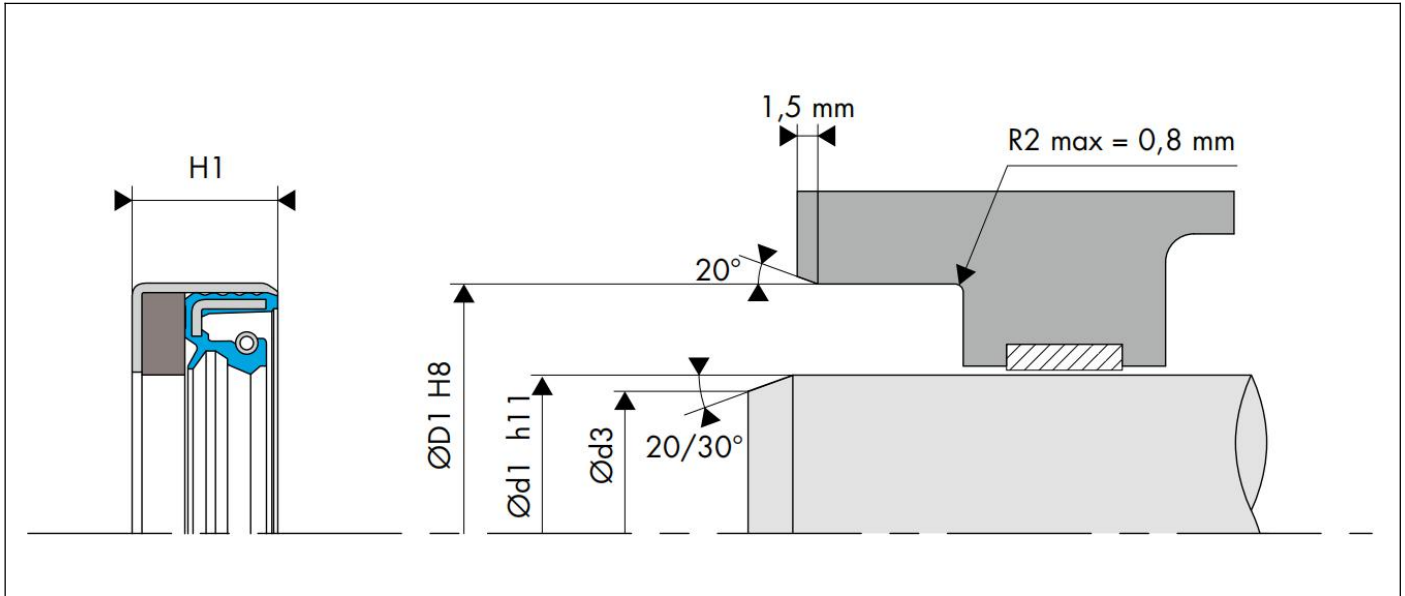

## 1. Description

Combi seals are inseparable entities linked by metal frames, composed of standard or custom-made shaft seals and polyurethane anti-pollution deflectors. They are particularly valued for their great ability to form an anti-pollution barrier. Combination of a Simmerring and an additional seal against dirt from the outside in one housing. Primarily for usage in all applications with high level of soiling, e.g., in axles for off-road vehicles.

## 2. Installation Recommendation



## 3. Standard materials

NBR

## 4. Installation Dimensions

Inner Diam.	Outer Diam.	Height	Order No.
45	55	7	combi45*55*7
45	62	11.2	combi45*62*11.2
46	65	16	combi46*65*16
46	65	21	combi46*65*21
50	75	12	combi50*75*12
56	75	16	combi56*75*16
56	75	22.5	combi56*75*22.5
55	80	11	combi55*80*11
65	90	20	combi65*90*20
75	102	14	combi75*102*14