



泰丰机械



**TOPSTAR**  
Brush Machine

佛山市鑫泰丰机械有限公司  
**TOPSTAR CNC BRUSH MACHINE LIMITED**

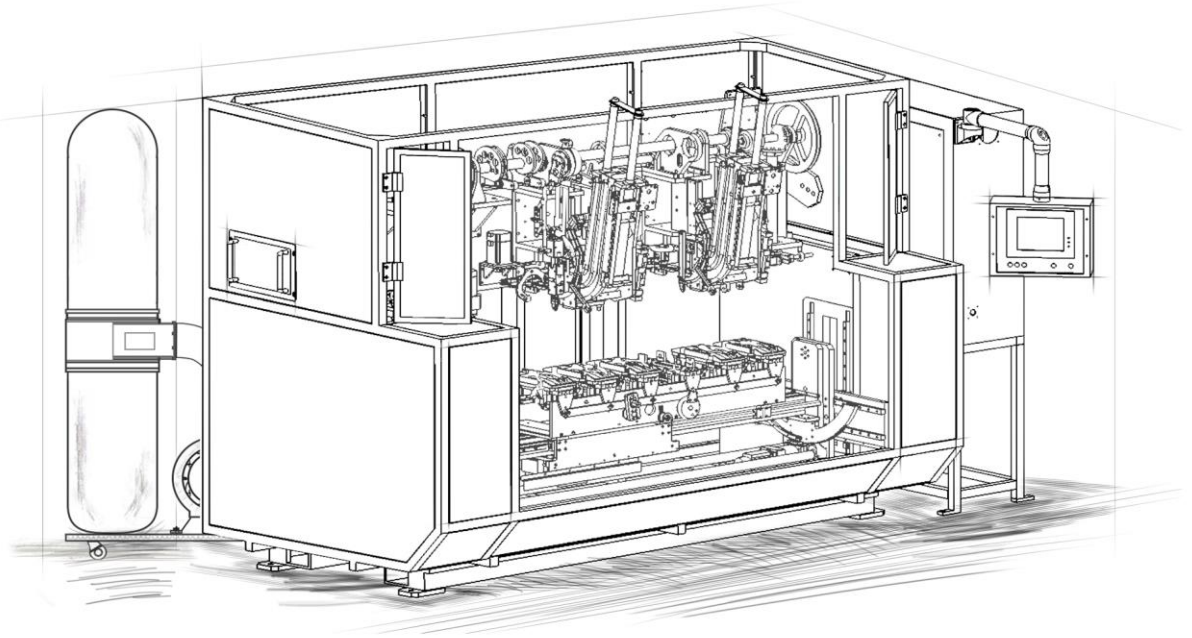

质量铸造品牌 • 口碑是最好的推销

Quality Casts Brand, Word Of Mouth Wins Customers

# 公司简介 Introduction

佛山市鑫泰丰制刷有限公司 成立于 2002 年，是一家集研发、生产、销售、服务于一体的国内大型的从事制刷机械设备的技术型企业。主要产品有五轴五头钻植一体机、五轴三头钻植一体机、八轴三合一钻植一体机、二/三/四/五轴高速植毛机、钢丝刷钻孔植毛机等。辅助设备有自动平毛开花一体机、球型刷自动平毛机、简易平毛机、气动切毛机等制刷机械设备。同时也可根据客户要求研制开发特殊制刷机械。

泰丰机械以成为“卓越的制刷机械和解决方案提供商”为企业愿景，经过十多年的发展，拥有一批长期从事制刷数控机械制造的高级设计工程师、技术人员和销售人员。产品获得欧盟 CE 认证，销售网络遍布国内外 50 多个国家和地区。

“团结、务实、创新、进取”是泰丰机械的企业精神，“持续为客户创造价值”是泰丰机械的企业使命。在未来的发展中，泰丰机械将继续坚守“质量铸造品牌、口碑赢取客户”的经营方针，不断推陈出新，为客户提供更高品质的产品和快捷优质的服务！



**TOPSTAR CNC BRUSH MACHINE LIMITED** was established in 2002, is a collection R&D, production, sales and service of domestic leading brush machinery manufacturing enterprise. The main products are 5 axis 5 head drilling and filling machine, 5 axis 3 head drilling and filling machine, 8 axis 3-in-1 drilling and filling machine, 2 / 3 / 4 / 5 axis high speed tufting machine, wire brush drilling and tufting machine, etc. The auxiliary machines are automatic trimming and flagging machine, automatic spherical brush trimming machine, manual trimmer, pneumatic cutting machine and other brush machines. Also, we can design and produce special brush machinery according to customers' requirements.

The company vision is to be an "Excellent Brush Machinery and Solutions Provider". After more than 10 years of development, TOPSTAR has a batch of design engineers, technicians, and sales who engaged in the brush CNC machinery manufacturing for years. Products got CE approved, hot-selling at home and abroad for more than 50 countries and areas, and striving to develop agency partners in Europe, South America, Middle East, and other regions.

"Unity, pragmatism, innovation and progress" are the corporate spirit of TOPSTAR. "Continue to create value for customers" is our business mission. In the future development, TOPSTAR will continue to adhere to the operating principle of "Quality casts brand, word of mouth wins customers", continue innovation, to provide customers with higher quality products and excellent service!

# 五轴三头钻植一体机

## 5 Axis 3 Head Drilling and Filling Machine

型号 Model:  
LZY-130P/180P-TG3

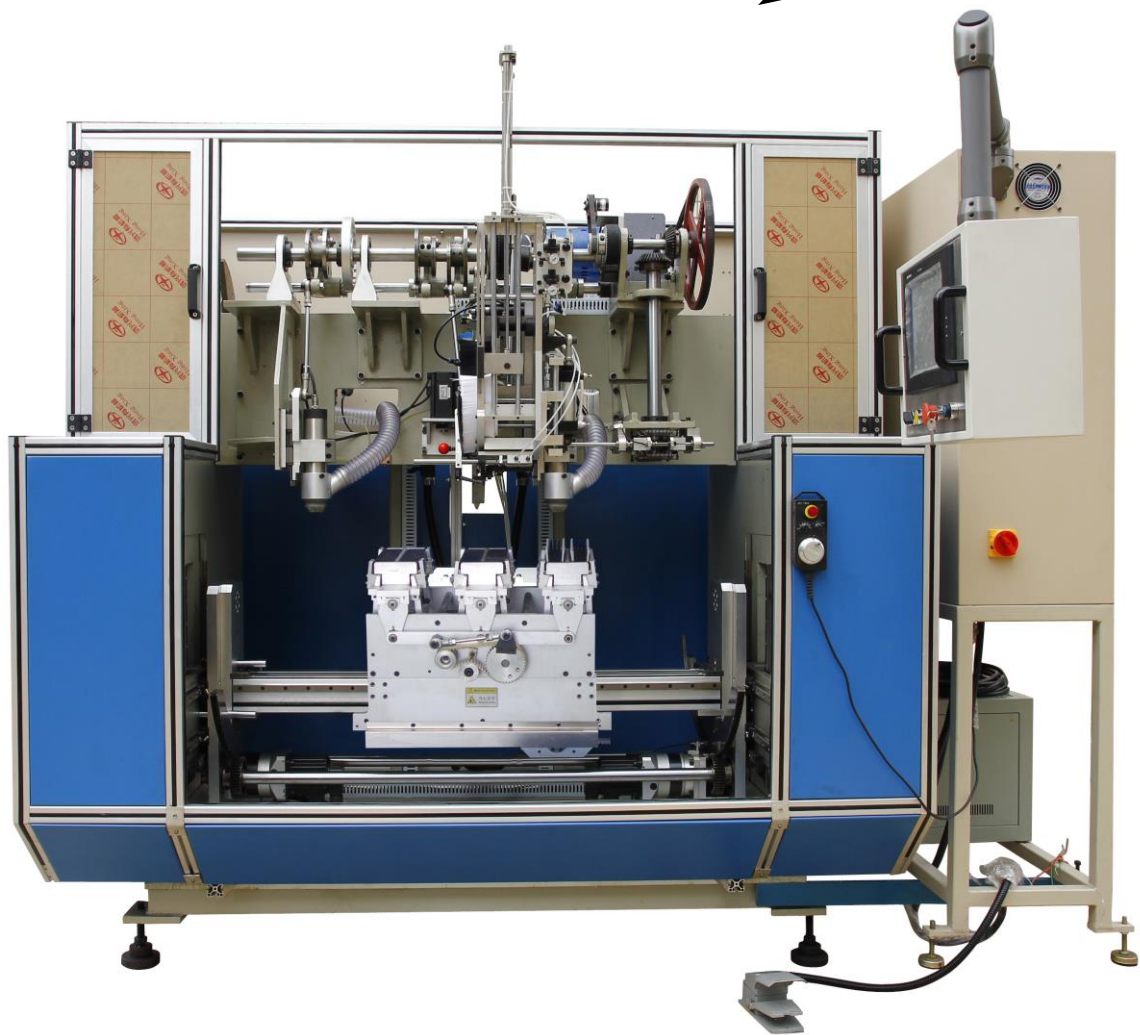

| 技术参数 Technical Parameters            |                                   |                                   |
|--------------------------------------|-----------------------------------|-----------------------------------|
| 型号 Model                             | LZY-130P-TG3                      | LZY-180P-TG3L                     |
| 轴数 Axes                              | 5                                 | 5                                 |
| 夹具 Fixture                           | 3                                 | 3                                 |
| 植毛方式 Tufting Type                    | 马钉 Stapling wire                  |                                   |
| 速度 Speed (r/min)                     | 450                               | 420                               |
| 出锋 Length of fiber outside hole (mm) | 17 ~ 130                          | 17 ~ 180                          |
| 毛长 Total length of fiber (mm)        | 40 ~ 270                          | 40 ~ 400                          |
| 孔径 Diameter of hole (mm)             | 2.8 ~ 6.5                         | 2.8 ~ 8.0                         |
| 毛的直径 Diameter of fiber (mm)          | 0.07 ~ 1.5mm                      |                                   |
| 颜色 Color                             | 双色 Double colors                  |                                   |
| 总功率 Total power (KW)                 | 11                                | 11.5                              |
| 额定电压 Voltage (V)                     | 380V / 220V                       | 380V / 220V                       |
| 气压 Air consumption (mpa.)            | 0.4 - 0.6                         | 0.4 - 0.6                         |
| 尺寸 Dimensions (L x W x H cm)         | 212 x 146 x 245<br>130 x 40 x 200 | 212 x 146 x 250<br>130 x 40 x 200 |
| 重量 Net weight (kgs)                  | 2800                              | 3000                              |

## 机器特性

- 本机两钻一植的设计，配合工作台三个工位三或六个夹具，实现循环切换工件，提高工作效率。
- 可选配圆式平台、平式平台或辊式平台生产不同类型的刷子。
- 人机触摸屏控制系统，操作灵活方便。
- 支持同步钻植、单钻孔、单植毛等加工模式。
- 单、双色植毛可任意选择。
- 具有插孔，分孔，阵列，偏移，修改等多种编辑功能，编程简单快捷。
- 可存放 1000 款不同刷子程序，支持外接 USB。
- 植毛配件均采用标准化设计，实现多工序精加工，光洁耐用，便于更换。
- 自动供油润滑系统，定时对具有高频率工作的零件进行自动注油和润滑，减缓磨损。
- 产品已获得欧盟 CE 认证。

## Machine Features

- Designed by 2 drillings and 1 tufting, equipped with 3 stations 3 or 6 fixtures, machine works in continuous cycle, high efficiency.
- Optional round, flat or roller platforms for different types of brushes.
- Touch screen control system, Chinese and English version, flexible and convenient operation.
- Support synchronous drilling and tufting, single drilling, single tufting and other processing modes.
- Single color and double colors are optional.
- With insert, division, array, offset, modify and other functions, easy to program.
- Can save 1000 different brushes programs, support external USB.
- Tufting accessories are standardized designs, achieve multi-process finishing, beautiful and durable.
- Automatic oil lubrication system, regularly and automatically lubricate the parts with high frequency operation, reduce wear and tear.
- Machine got CE approved.



# 五轴三头钻植一体机

## 5 Axis 3 Head Drilling and Filling Machine

型号 Model:  
LZY-130Q/180Q-TG3

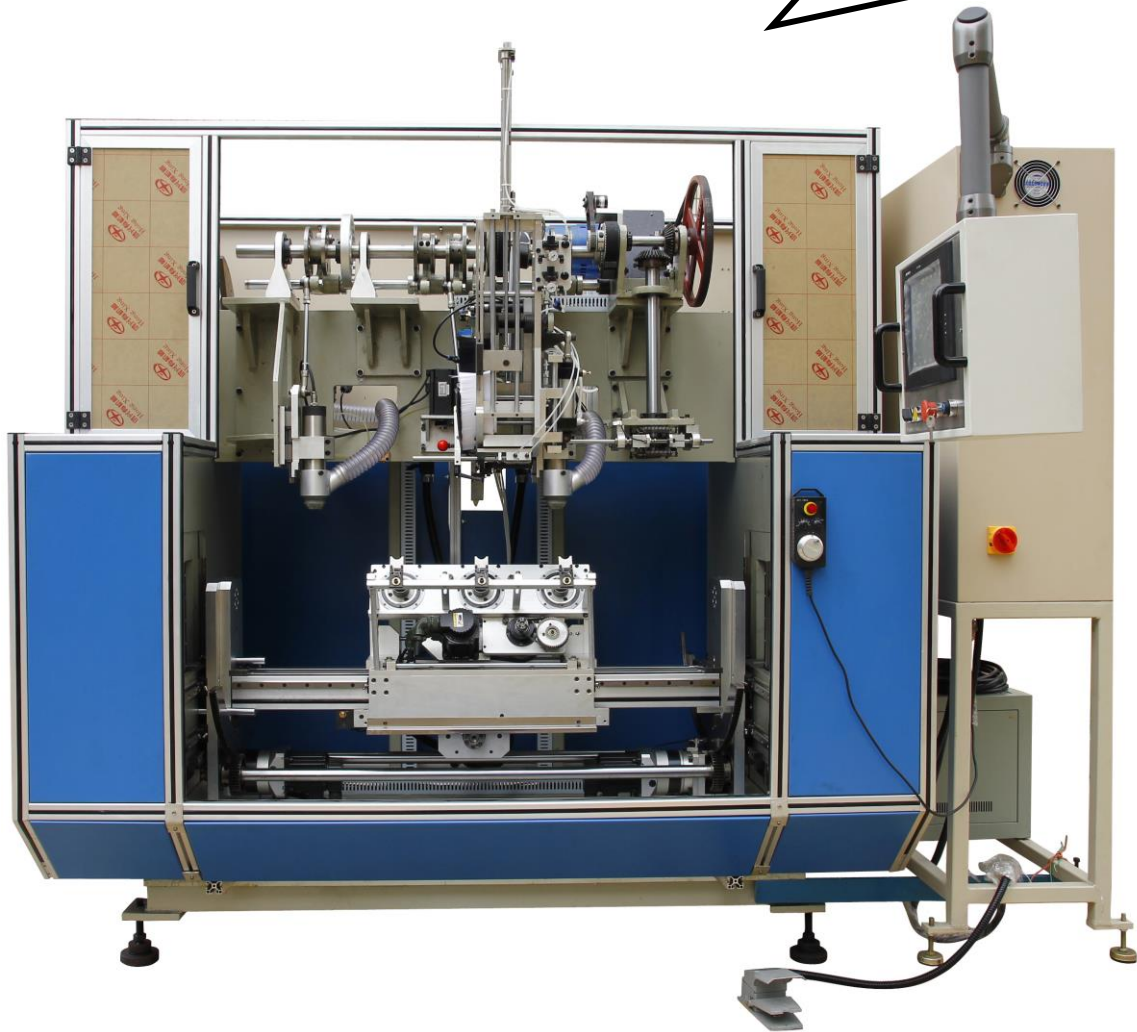

| 技术参数 Technical Parameters            |                                   |                                   |
|--------------------------------------|-----------------------------------|-----------------------------------|
| 型号 Model                             | LZY-130Q-TG3                      | LZY-180Q-TG3L                     |
| 轴数 Axes                              | 5                                 | 5                                 |
| 夹具 Fixture                           | 3                                 | 3                                 |
| 植毛方式 Tufting Type                    | 马钉 Stapling wire                  |                                   |
| 速度 Speed (r/min)                     | 450                               | 420                               |
| 出锋 Length of fiber outside hole (mm) | 17 ~ 130                          | 17 ~ 180                          |
| 毛长 Total length of fiber (mm)        | 40 ~ 270                          | 40 ~ 400                          |
| 孔径 Diameter of hole (mm)             | 2.8 ~ 6.5                         | 2.8 ~ 8.0                         |
| 毛的直径 Diameter of fiber (mm)          | 0.07 ~ 1.5mm                      |                                   |
| 颜色 Color                             | 双色 Double colors                  |                                   |
| 总功率 Total power (KW)                 | 11                                | 11.5                              |
| 额定电压 Voltage (V)                     | 380V / 220V                       | 380V / 220V                       |
| 气压 Air consumption (mpa.)            | 0.4 - 0.6                         | 0.4 - 0.6                         |
| 尺寸 Dimensions (L x W x H cm)         | 212 x 146 x 245<br>130 x 40 x 200 | 212 x 146 x 250<br>130 x 40 x 200 |
| 重量 Net weight (kgs)                  | 2800                              | 3000                              |

## 机器特性

- 本机两钻一植的设计，配合工作台三个工位三个夹具，实现循环切换工件，提高工作效率。
- 可选配圆式平台、平式平台或辊式平台生产不同类型的刷子。
- 人机触摸屏控制系统，操作灵活方便。
- 支持同步钻植、单钻孔、单植毛等加工模式。
- 单、双色植毛可任意选择。
- 具有插孔，分孔，阵列，偏移，修改等多种编辑功能，编程简单快捷。
- 可存放 1000 款不同刷子程序，支持外接 USB。
- 植毛配件均采用标准化设计，实现多工序精加工，光洁耐用，便于更换。
- 自动供油润滑系统，定时对具有高频率工作的零件进行自动注油和润滑，减缓磨损。
- 产品已获得欧盟 CE 认证。

## Machine Features

- Designed by 2 drillings and 1 tufting, equipped with 3 stations 3 fixtures, machine works in continuous cycle, high efficiency.
- Optional round, flat or roller platforms for different types of brushes.
- Touch screen control system, Chinese and English version, flexible and convenient operation.
- Support synchronous drilling and tufting, single drilling, single tufting and other processing modes.
- Single color and double colors are optional.
- With insert, division, array, offset, modify and other functions, easy to program.
- Can save 1000 different brushes programs, support external USB.
- Tufting accessories are standardized designs, achieve multi-process finishing, beautiful and durable.
- Automatic oil lubrication system, regularly and automatically lubricate the parts with high frequency operation, reduce wear and tear.
- Machine got CE approved.

# 五轴五头钻植一体机

## 5 Axis 5 Head Drilling and Filling Machine

型号 Model:  
SZL-130Q/180Q-TG6

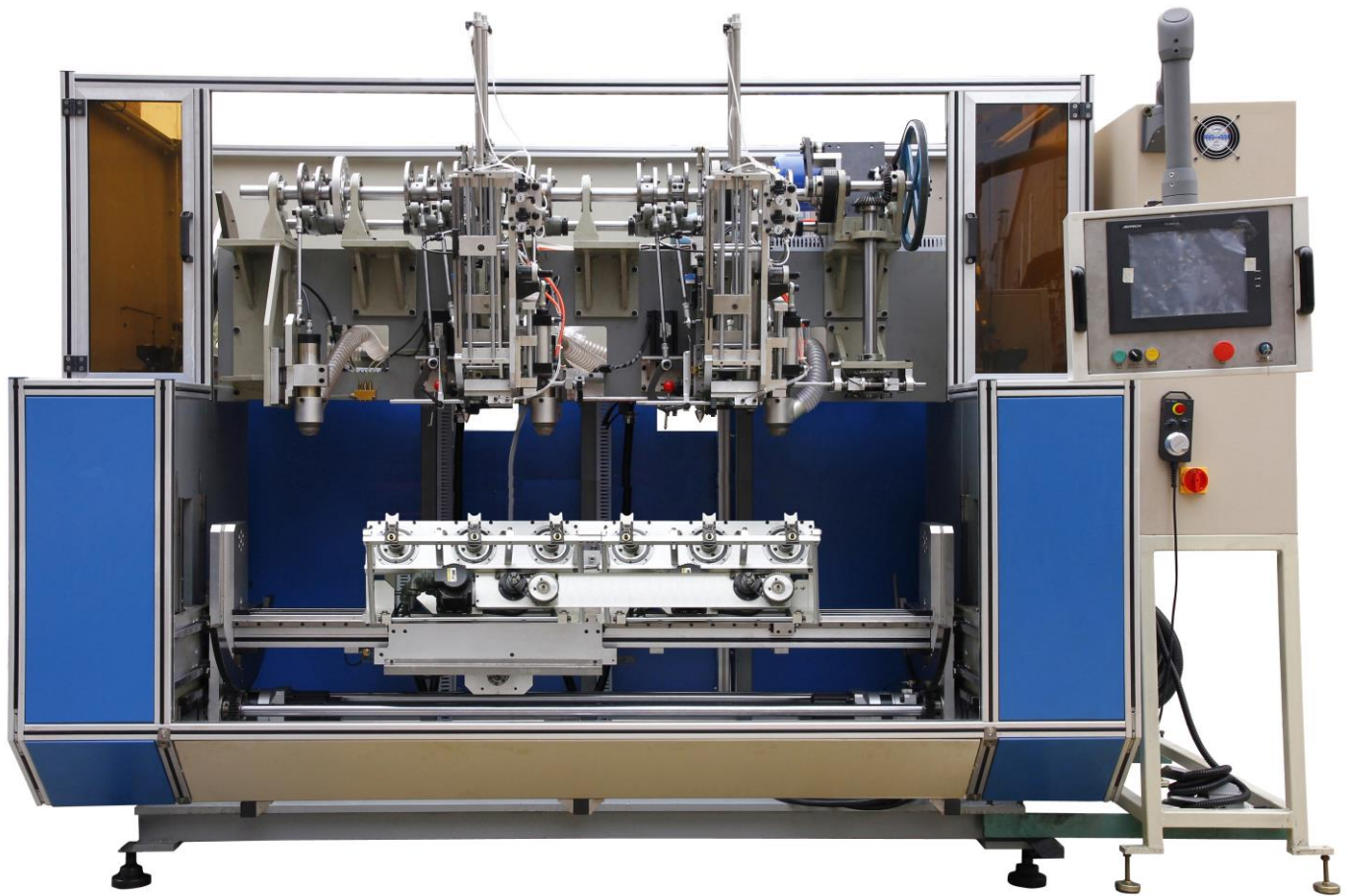

| 技术参数 Technical Parameters            |                                   |                                   |
|--------------------------------------|-----------------------------------|-----------------------------------|
| 型号 Model                             | SZL-130Q-TG6                      | SZL-180Q-TG6L                     |
| 轴数 Axes                              | 5                                 | 5                                 |
| 夹具 Fixture                           | 6                                 | 6                                 |
| 植毛方式 Tufting Type                    | 马钉 Stapling wire                  |                                   |
| 速度 Speed (r/min)                     | 840                               | 720                               |
| 出锋 Length of fiber outside hole (mm) | 17 ~ 130                          | 17 ~ 180                          |
| 毛长 Total length of fiber (mm)        | 40 ~ 270                          | 40 ~ 400                          |
| 孔径 Diameter of hole (mm)             | 2.8 ~ 6.5                         | 2.8 ~ 8.0                         |
| 毛的直径 Diameter of fiber (mm)          | 0.07 ~ 1.5mm                      |                                   |
| 颜色 Color                             | 双色 Double colors                  |                                   |
| 总功率 Total power (KW)                 | 13                                | 13.5                              |
| 额定电压 Voltage (V)                     | 380V / 220V                       | 380V / 220V                       |
| 气压 Air consumption (mpa.)            | 0.4 - 0.6                         | 0.4 - 0.6                         |
| 尺寸 Dimensions (L x W x H cm)         | 276 x 146 x 245<br>130 x 40 x 200 | 276 x 146 x 250<br>130 x 40 x 200 |
| 重量 Net weight (kgs)                  | 3300                              | 3500                              |

## 机器特性

- 本机三钻两植的设计，配合工作台六个工位六个夹具，实现循环切换工件，提高工作效率。
- 可选配圆式平台、平式平台或辊式平台生产不同类型的刷子。
- 人机触摸屏控制系统，操作灵活方便。
- 支持同步钻植、单钻孔、单植毛等加工模式。
- 单、双色植毛可任意选择。
- 具有插孔，分孔，阵列，偏移，修改等多种编辑功能，编程简单快捷。
- 可存放 1000 款不同刷子程序，支持外接 USB。
- 植毛配件均采用标准化设计，实现多工序精加工，光洁耐用，便于更换。
- 自动供油润滑系统，定时对具有高频率工作的零件进行自动注油和润滑，减缓磨损。
- 产品已获得欧盟 CE 认证。

## Machine Features

- Designed by 3 drillings and 2 fillings, equipped with 6 stations 6 fixtures, machine works in continuous cycle, high efficiency.
- Optional round, flat or roller platforms for different types of brushes.
- Touch screen control system, Chinese and English version, flexible and convenient operation.
- Support synchronous drilling and tufting, single drilling, single tufting and other processing modes.
- Single color and double colors are optional.
- With insert, division, array, offset, modify and other functions, easy to program.
- Can save 1000 different brushes programs, support external USB.
- Tufting accessories are standardized designs, achieve multi-process finishing, beautiful and durable.
- Automatic oil lubrication system, regularly and automatically lubricate the parts with high frequency operation, reduce wear and tear.
- Machine got CE approved.



# 五轴五头钻植一体机

## 5 Axis 5 Head Drilling and Filling Machine

型号 Model:  
SZL-130P/180P-TG12

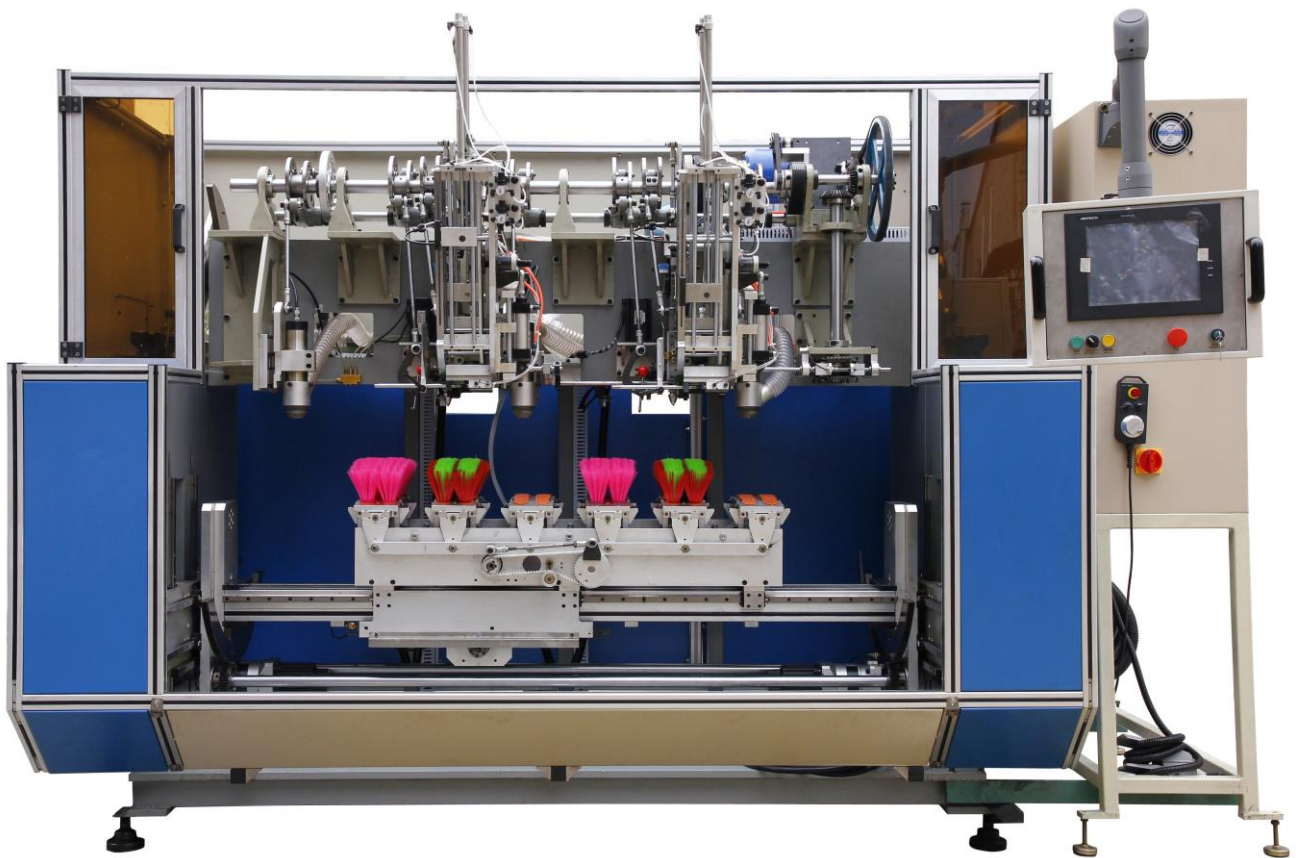

| 技术参数 Technical Parameters            |                                   |                                   |
|--------------------------------------|-----------------------------------|-----------------------------------|
| 型号 Model                             | SZL-130P-TG12                     | SZL-180P-TG12L                    |
| 轴数 Axes                              | 5                                 | 5                                 |
| 夹具 Fixture                           | 12                                | 12                                |
| 植毛方式 Tufting Type                    | 马钉 Stapling wire                  |                                   |
| 速度 Speed (r/min)                     | 840                               | 720                               |
| 出锋 Length of fiber outside hole (mm) | 17 ~ 130                          | 17 ~ 180                          |
| 毛长 Total length of fiber (mm)        | 40 ~ 270                          | 40 ~ 400                          |
| 孔径 Diameter of hole (mm)             | 2.8 ~ 6.5                         | 2.8 ~ 8.0                         |
| 毛的直径 Diameter of fiber (mm)          | 0.07 ~ 1.5mm                      |                                   |
| 颜色 Color                             | 双色 Double colors                  |                                   |
| 总功率 Total power (KW)                 | 13                                | 13.5                              |
| 额定电压 Voltage (V)                     | 380V / 220V                       | 380V / 220V                       |
| 气压 Air consumption (mpa.)            | 0.4 - 0.6                         | 0.4 - 0.6                         |
| 尺寸 Dimensions (L x W x H cm)         | 276 x 146 x 245<br>130 x 40 x 200 | 276 x 146 x 250<br>130 x 40 x 200 |
| 重量 Net weight (kgs)                  | 3300                              | 3500                              |

## 机器特性

- 本机三钻两植的设计，配合工作台六个工位十二个夹具，实现循环切换工件，提高工作效率。
- 可选配圆式平台、平式平台或辊式平台生产不同类型的刷子。
- 人机触摸屏控制系统，操作灵活方便。
- 支持同步钻植、单钻孔、单植毛等加工模式。
- 单、双色植毛可任意选择。
- 具有插孔，分孔，阵列，偏移，修改等多种编辑功能，编程简单快捷。
- 可存放 1000 款不同刷子程序，支持外接 USB。
- 植毛配件均采用标准化设计，实现多工序精加工，光洁耐用，便于更换。
- 自动供油润滑系统，定时对具有高频率工作的零件进行自动注油和润滑，减缓磨损。
- 产品已获得欧盟 CE 认证。

## Machine Features

- Designed by 3 drillings and 2 fillings, equipped with 6 stations 12 fixtures, machine works in continuous cycle, high efficiency.
- Optional round, flat or roller platforms for different types of brushes.
- Touch screen control system, Chinese and English version, flexible and convenient operation.
- Support synchronous drilling and tufting, single drilling, single tufting and other processing modes.
- Single color and double colors are optional.
- With insert, division, array, offset, modify and other functions, easy to program.
- Can save 1000 different brushes programs, support external USB.
- Tufting accessories are standardized designs, achieve multi-process finishing, beautiful and durable.
- Automatic oil lubrication system, regularly and automatically lubricate the parts with high frequency operation, reduce wear and tear.
- Machine got CE approved.

# 八轴三合一钻植一体机

## 8 Axis 3-In-1 Drilling and Filling Machine

型号 Model:  
YB-B130/B250/B300-DC8

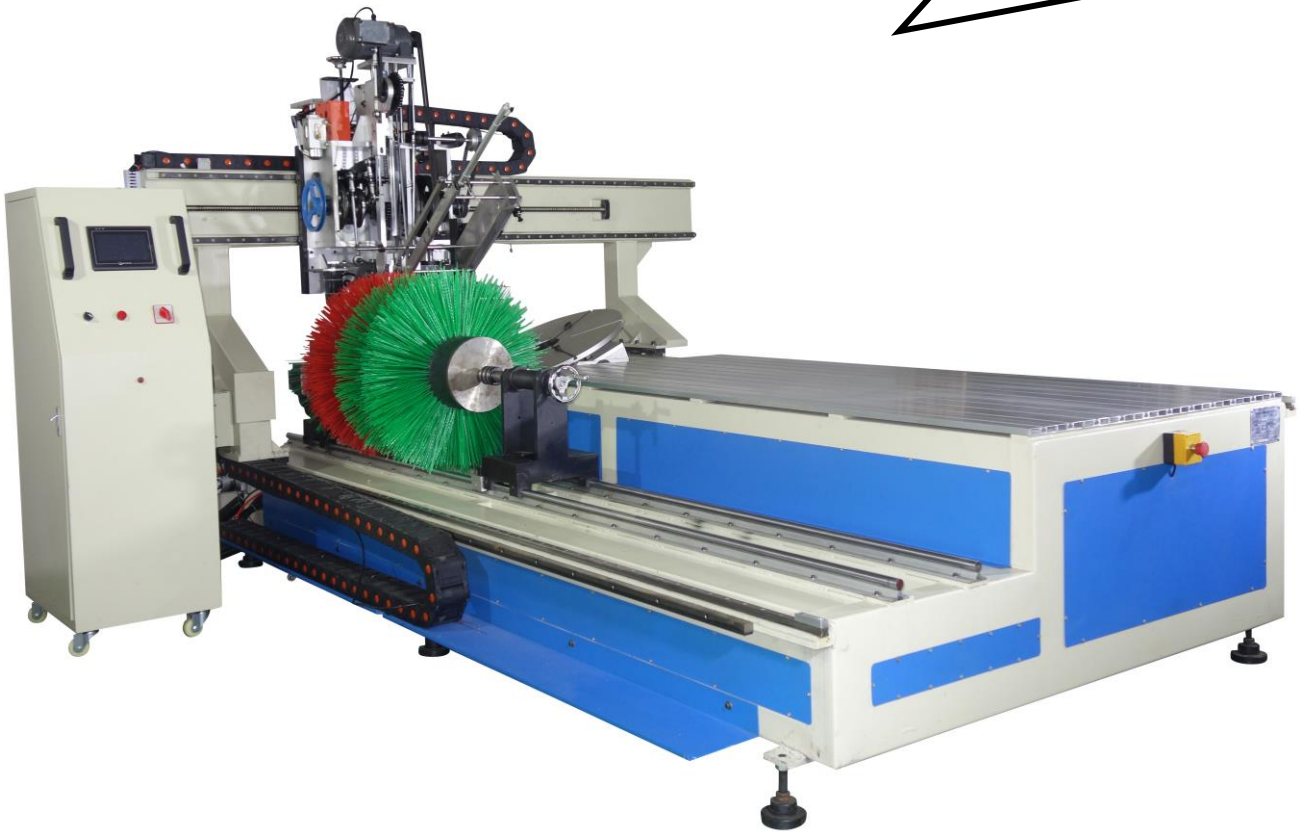

| 技术参数 Technical Parameters            |                                    |                                  |                 |
|--------------------------------------|------------------------------------|----------------------------------|-----------------|
| 型号 Model                             | YB-B130-DC8A                       | YB-B250-DC8B                     | YB-B300-DC8L    |
| 轴数 Axes                              | 8                                  | 8                                | 8               |
| 夹具 Fixture                           | 3                                  | 3                                | 3               |
| 植毛方式 Tufting Type                    | 马钉 Stapling wire                   |                                  |                 |
| 速度 Speed (r/min)                     | 240                                | 180                              | 120             |
| 出锋 Length of fiber outside hole (mm) | 17 ~ 130                           | 17 ~ 250                         | 17 ~ 300        |
| 毛长 Total length of fiber (mm)        | 40 ~ 270                           | 40 ~ 600                         | 40 ~ 650        |
| 孔径 Diameter of hole (mm)             | 2.8 ~ 6.5                          | 3.0 ~ 10.0                       | 4.0 ~ 12.0      |
| 毛的直径 Diameter of fiber (mm)          | 0.07 ~ 1.5mm, PP 3*2mm             |                                  |                 |
| 颜色 Color                             | 单色 Single color / 双色 Double colors |                                  |                 |
| 总功率 Total power (KW)                 | 9                                  | 10                               | 11              |
| 额定电压 Voltage (V)                     | 380V / 220V                        | 380V / 220V                      | 380V / 220V     |
| 气压 Air consumption (mpa.)            | 0.4 - 0.6                          | 0.4 - 0.6                        | 0.4 - 0.6       |
| 尺寸 Dimensions (L x W x H cm)         | 370 x 265 x 196<br>45 x 65 x 147   | 370 x 280 x 225<br>45 x 65 x 147 | 370 x 280 x 265 |
| 重量 Net weight (kgs)                  | 1500                               | 2000                             | 2500            |

## 机器特性

- 本机为三合一功能一体机，一台机器可生产圆盘刷，长辊刷，条刷和板刷等大小型工业刷。专为出锋 300mm 以内，孔径 12mm 以内的大尺寸毛刷而设计。
- 采用移动式龙门架结构，平稳扎实，安全可靠。产品已获得欧盟 CE 认证。
- 人机触摸屏控制系统，操作灵活方便。
- 本机一钻一植的设计，支持混合钻植、先钻后植、同步钻植、单钻孔、单植毛等加工模式。
- 可编辑如直线型，梅花型，V 型，螺旋型，梯型，U 型等多种孔位排列模式。
- 产品数据采用排为单位，整个系统可存放 999 排，每排可存 9999 孔，每孔最多可扩充 255 个步进孔。产品编号共 32 组，支持外接 USB。
- 植毛配件均采用标准化设计，实现多工序精加工，光洁耐用，便于更换。

## Machine Features

- It is a 3-in-1 integrated machine, which is able to produce disc brush, roller brush, lath brush/board brush and other industrial technical brushes. Special for road sweeping brush with 12mm hole diameter and 300mm filament length after fold.
- Adopt moveable gantry structure, stable and solid, safe and reliable. Machine got CE approved.
- Touch screen control system, with insert, division, expansion, offset, stepping hole and other functions, easy to program.
- Designed by 1 drilling and 1 tufting, support mixed drill and fill, drill fist then fill, sync drill and fill, single drill, single fill and other processing modes.
- Can program different hole pattern, such as straight, staggered, spiral, Ladder-shaped, V-shape, U-shape, etc.
- Unit of product data is in rows. The entire system can store 999 rows, each row can store 9999 holes, and each hole can expand 255 stepping holes. Divide into 32 product numbers, support external USB.
- Tufting accessories are standardized designs, achieve multi-process finishing, beautiful and durable.



## 二轴长辊刷钻植一体机

## 2 Axis Roller Brush Drilling and Filling Machine

型号 Model:  
HSD-130/250/300-DC2



| 技术参数 Technical Parameters            |                                    |                                  |                                  |
|--------------------------------------|------------------------------------|----------------------------------|----------------------------------|
| 型号 Model                             | HSD-130-DC2A                       | HSD-250-DC2B                     | HSD-300-DC2L                     |
| 轴数 Axes                              | 2                                  | 2                                | 2                                |
| 夹具 Fixture                           | 1                                  | 1                                | 1                                |
| 植毛方式 Tufting Type                    | 马钉 Stapling wire                   |                                  |                                  |
| 速度 Speed (r/min)                     | 300                                | 180                              | 120                              |
| 出锋 Length of fiber outside hole (mm) | 17 ~ 130                           | 17 ~ 250                         | 17 ~ 300                         |
| 毛长 Total length of fiber (mm)        | 40 ~ 270                           | 40 ~ 600                         | 40 ~ 650                         |
| 孔径 Diameter of hole (mm)             | 2.8 ~ 6.5                          | 3.0 ~ 10.0                       | 4.0 ~ 12.0                       |
| 毛的直径 Diameter of fiber (mm)          | 0.07 ~ 1.5mm, PP 3*2mm             |                                  |                                  |
| 颜色 Color                             | 单色 Single color / 双色 Double colors |                                  |                                  |
| 总功率 Total power (KW)                 | 5                                  | 6                                | 6.5                              |
| 额定电压 Voltage (V)                     | 380V / 220V                        | 380V / 220V                      | 380V / 220V                      |
| 气压 Air consumption (mpa.)            | 0.4 - 0.6                          | 0.4 - 0.6                        | 0.4 - 0.6                        |
| 尺寸 Dimensions (L x W x H cm)         | 370 x 180 x 196<br>45 x 65 x 147   | 370 x 205 x 225<br>45 x 65 x 147 | 370 x 215 x 265<br>45 x 65 x 147 |
| 重量 Net weight (kgs)                  | 1000                               | 1500                             | 2000                             |

## 机器特性

- 本机专为各种圆辊刷设计，辊刷植毛长度可达 2500mm，管径 300mm，出锋 300mm。
- 机器结构稳固扎实，机头移动平稳，安全可靠。产品已获得欧盟 CE 认证。
- 单、双色植毛可任意选择。
- 人机触摸屏控制系统，操作灵活方便。
- 本机一钻一植的设计，支持混合钻植、先钻后植、同步钻植、单钻孔、单植毛等加工模式。
- 可编辑如直线型，梅花型，V 型，螺旋型，梯型，U 型等多种孔位排列模式。
- 产品数据采用排为单位，整个系统可存放 999 排，每排可存 9999 孔，每孔最多可扩充 255 个步进孔。产品编号共 32 组，支持外接 USB。
- 植毛配件均采用标准化设计，实现多工序精加工，光洁耐用，便于更换。

## Machine Features

- Special design for different roller brushes / cylinder brushes / zig zag brushes, brush length up to 2500mm, outer diameter of pipe up to 300mm, and filament length outside hole up to 300mm.
- Strong machine structure, stable and solid, safe and reliable. Machine got CE approved.
- Single color and double colors are optional.
- Touch screen control system, with insert, division, expansion, offset, stepping hole and other functions, easy to program.
- Designed by 1 drilling and 1 tufting, support mixed drill and fill, drill fist then fill, sync drill and fill, single drill, single fill and other processing modes.
- Can program different hole pattern, such as straight, staggered, spiral, Ladder-shaped, V-shape, U-shape, etc.
- Unit of product data is in rows. The entire system can store 999 rows, each row can store 9999 holes, and each hole can expand 255 stepping holes. Divide into 32 product numbers, support external USB.
- Tufting accessories are standardized designs, achieve multi-process finishing, beautiful and durable.

## 二轴单头高速植毛机

### 2 Axis Single Head High Speed Tufting Machine

型号 Model:  
SBJ-130BX2/180BX2-SF2A



| 技术参数 Technical Parameters            |                                 |                                 |
|--------------------------------------|---------------------------------|---------------------------------|
| 型号 Model                             | SBJ-130BX2-SF2A                 | SBJ-180BX2-SF2AL                |
| 轴数 Axes                              | 2                               | 2                               |
| 夹具 Fixture                           | 2                               | 2                               |
| 植毛方式 Tufting Type                    | 扁线 Flat wire / 马钉 Stapling wire |                                 |
| 速度 Speed (r/min)                     | 450                             | 420                             |
| 出锋 Length of fiber outside hole (mm) | 17 ~ 130                        | 17 ~ 180                        |
| 毛长 Total length of fiber (mm)        | 40 ~ 270                        | 40 ~ 400                        |
| 孔径 Diameter of hole (mm)             | 2.0 ~ 5.0 / 2.8 ~ 6.5           |                                 |
| 毛的直径 Diameter of fiber (mm)          | 0.07 ~ 1.5mm                    | 0.07 ~ 1.5mm                    |
| 颜色 Color                             | 双色 Double colors                | 双色 Double colors                |
| 总功率 Total power (KW)                 | 2                               | 2                               |
| 额定电压 Voltage (V)                     | 380V / 220V                     | 380V / 220V                     |
| 气压 Air consumption (mpa.)            | 0.4 - 0.6                       | 0.4 - 0.6                       |
| 尺寸 Dimensions (L x W x H cm)         | 120 x 91 x 180<br>41 x 35 x 104 | 120 x 91 x 196<br>41 x 35 x 104 |
| 重量 Net weight (kgs)                  | 450                             | 450                             |

## 机器特性

- 本机特别适用于各种平面毛刷，如扫把，洗衣刷，床刷等。
- 机头采用高速植毛系统，植毛速度可高达 7 孔每秒。
- 配合工作台双工位，实现循环切换工件，提高工作效率。
- 单、双色植毛可任意选择。
- 人机触摸屏控制系统，操作灵活方便。
- 具有插孔，分孔，阵列，偏移，修改等多种编辑功能，编程简单快捷。
- 可存放 128 款不同刷子程序，支持外接 USB。
- 植毛配件均采用标准化设计，实现多工序加工，光洁耐用，便于更换。
- 产品已获得欧盟 CE 认证。

## Machine Features

- Suitable for pre-hole brushes in flat shape, such as broom, scrub brush, bed brush, and so on.
- Adopt high-speed machine head system. Speed reaches 7 holes per second.
- Equipped with a worktable 2 stations, machine works in continuous cycle, high efficiency.
- Single color and double colors are optional.
- Touch screen control system, Chinese and English versions, flexible and convenient operation.
- With insert, division, array, offset, modify and other functions, easy to program.
- Can save 128 different brushes programs, support external USB.
- Tufting accessories are standardized designs, durable, and easy to repair and replace.
- Machine got CE approved.



# 三轴单头高速植毛机

## 3 Axis Single Head High Speed Tufting Machine

型号 Model:  
SBJ-130BX3/180BX3-SF3A



| 技术参数 Technical Parameters            |                                 |                  |
|--------------------------------------|---------------------------------|------------------|
| 型号 Model                             | SBJ-130BX3-SF3A                 | SBJ-180BX3-SF3AL |
| 轴数 Axes                              | 3                               | 3                |
| 夹具 Fixture                           | 2                               | 2                |
| 植毛方式 Tufting Type                    | 扁线 Flat wire / 马钉 Stapling wire |                  |
| 速度 Speed (r/min)                     | 450                             | 420              |
| 出锋 Length of fiber outside hole (mm) | 17 ~ 130                        | 17 ~ 180         |
| 毛长 Total length of fiber (mm)        | 40 ~ 270                        | 40 ~ 400         |
| 孔径 Diameter of hole (mm)             | 2.0 ~ 5.0 / 2.8 ~ 6.5           |                  |
| 毛的直径 Diameter of fiber (mm)          | 0.07 ~ 1.5mm                    | 0.07 ~ 1.5mm     |
| 颜色 Color                             | 双色 Double colors                | 双色 Double colors |
| 总功率 Total power (KW)                 | 2.8                             | 2.8              |
| 额定电压 Voltage (V)                     | 380V / 220V                     | 380V / 220V      |
| 气压 Air consumption (mpa.)            | 0.4 - 0.6                       | 0.4 - 0.6        |
| 尺寸 Dimensions (L x W x H cm)         | 120 x 91 x 180                  | 120 x 91 x 196   |
|                                      | 41 x 35 x 104                   | 41 x 35 x 104    |
| 重量 Net weight (kgs)                  | 450                             | 450              |

## 机器特性

- 本机适用于各种规则弧形，圆形和平面的毛刷，如扇形的厕所刷，天花板刷，小型辊刷，纺织机定型刷，扫把，洗衣刷等。
- 机头采用高速植毛系统，植毛速度可高达 7 孔每秒。
- 配合工作台双工位，实现循环切换工件，提高工作效率。
- 单、双色植毛可任意选择。
- 人机触摸屏控制系统，操作灵活方便。
- 具有插孔，分孔，阵列，偏移，修改等多种编辑功能，编程简单快捷。
- 可存放 128 款不同刷子程序，支持外接 USB。
- 植毛配件均采用标准化设计，实现多工序加工，光洁耐用，便于更换。
- 产品已获得欧盟 CE 认证。

## Machine Features

- Suitable for pre-hole brushes in regular curved shape, round shape and flat shape, such as single hockey brush, ceiling brush, small cylinder brush, stenter brush, broom, scrub brush, and so on.
- Adopt high-speed machine head system. Speed reaches 7 holes per second.
- Equipped with a worktable 2 stations, machine works in continuous cycle, high efficiency.
- Single color and double colors are optional.
- Touch screen control system, Chinese and English versions, flexible and convenient operation.
- With insert, division, array, offset, modify and other functions, easy to program.
- Can save 128 different brushes programs, support external USB.
- Tufting accessories are standardized designs, durable, and easy to repair and replace.
- Machine got CE approved.

# 四轴单头高速植毛机

## 4 Axis Single Head High Speed Tufting Machine

型号 Model:  
SBJ-130BX4/180BX4-SF4A



| 技术参数 Technical Parameters            |                                 |                                 |
|--------------------------------------|---------------------------------|---------------------------------|
| 型号 Model                             | SBJ-130BX4-SF4A                 | SBJ-180BX4-SF4AL                |
| 轴数 Axes                              | 4                               | 4                               |
| 夹具 Fixture                           | 2                               | 2                               |
| 植毛方式 Tufting Type                    | 扁线 Flat wire / 马钉 Stapling wire |                                 |
| 速度 Speed (r/min)                     | 450                             | 420                             |
| 出锋 Length of fiber outside hole (mm) | 17 ~ 130                        | 17 ~ 180                        |
| 毛长 Total length of fiber (mm)        | 40 ~ 270                        | 40 ~ 400                        |
| 孔径 Diameter of hole (mm)             | 2.0 ~ 5.0 / 2.8 ~ 6.5           |                                 |
| 毛的直径 Diameter of fiber (mm)          | 0.07 ~ 1.5mm                    | 0.07 ~ 1.5mm                    |
| 颜色 Color                             | 双色 Double colors                | 双色 Double colors                |
| 总功率 Total power (KW)                 | 3.5                             | 3.5                             |
| 额定电压 Voltage (V)                     | 380V / 220V                     | 380V / 220V                     |
| 气压 Air consumption (mpa.)            | 0.4 - 0.6                       | 0.4 - 0.6                       |
| 尺寸 Dimensions (L x W x H cm)         | 120 x 91 x 191<br>41 x 35 x 104 | 120 x 91 x 200<br>41 x 35 x 104 |
| 重量 Net weight (kgs)                  | 500                             | 500                             |

## 机器特性

- 可更换不同的平台和夹具生产各种平面、弧面、曲面的刷子，如扫把，洗衣刷，厕所刷，除尘刷，天花板刷等。
- 机头采用高速植毛系统，植毛速度可高达 7 孔每秒。
- 配合工作台双工位，实现循环切换工件，提高工作效率。
- 单、双色植毛可任意选择。
- 人机触摸屏控制系统，操作灵活方便。
- 具有插孔，分孔，阵列，偏移，修改等多种编辑功能，编程简单快捷。
- 可存放 128 款不同刷子程序，支持外接 USB。
- 植毛配件均采用标准化设计，实现多工序加工，光洁耐用，便于更换。
- 产品已获得欧盟 CE 认证。

## Machine Features

- Can be replaced by different platforms and fixtures to produce a variety of flat and curved brushes, such as broom, scrubbing brush, toilet brush, dust brush, ceiling brush and so on.
- Adopt high-speed machine head system. Speed reaches 7 holes per second.
- Equipped with a worktable 2 stations, machine works in continuous cycle, high efficiency.
- Single color and double colors are optional.
- Touch screen control system, Chinese and English versions, flexible and convenient operation.
- With insert, division, array, offset, modify and other functions, easy to program.
- Can save 128 different brushes programs, support external USB.
- Tufting accessories are standardized designs, durable, and easy to repair and replace.
- Machine got CE approved.



# 四轴单头高速植毛机

## 4 Axis Single Head High Speed Tufting Machine

型号 Model:  
GSJ-50HM/50HB-SF4AS



| 技术参数 Technical Parameters            |                  |                  |
|--------------------------------------|------------------|------------------|
| 型号 Model                             | GSJ50HB-SF4AS    | GSJ50HM-SF4AS    |
| 轴数 Axes                              | 4                |                  |
| 夹具 Fixture                           | 2                |                  |
| 植毛方式 Tufting Type                    | 扁线 Flat wire     | 马钉 Stapling wire |
| 速度 Speed (r/min)                     | 450              |                  |
| 出锋 Length of fiber outside hole (mm) | 17 ~ 50          |                  |
| 毛长 Total length of fiber (mm)        | 40 ~ 110         |                  |
| 孔径 Diameter of hole (mm)             | 2.0 ~ 5.0        | 2.8 ~ 6.5        |
| 毛的直径 Diameter of fiber (mm)          | 0.07 ~ 1.5mm     |                  |
| 颜色 Color                             | 双色 Double colors |                  |
| 总功率 Total power (KW)                 | 3                |                  |
| 额定电压 Voltage (V)                     | 380V / 220V      |                  |
| 气压 Air consumption (mpa.)            | 0.4 - 0.6        |                  |
| 尺寸 Dimensions (L x W x H cm)         | 104 x 91 x 180   | 41 x 35 x 104    |
| 重量 Net weight (kgs)                  | 450              |                  |

## 机器特性

- 本机特别适用于生产不带柄的菠萝头厕所刷，粗短磨料丝的烧烤刷，以及其它短小型毛刷等。
- 机头采用高速系统，植毛速度可高达 7 孔每秒。
- 配合工作台双工位，实现循环切换工件，提高工作效率。
- 单、双色植毛可任意选择。
- 人机触摸屏控制系统，操作灵活方便。
- 具有插孔，分孔，阵列，偏移，修改等多种编辑功能，编程简单快捷。
- 可存放 128 款不同刷子程序，支持外接 USB。
- 植毛配件均采用标准化设计，实现多工序加工，光洁耐用，便于更换。
- 产品已获得欧盟 CE 认证。

## Machine Features

- Special for pre-hole round toilet brush without handle, grill/BBQ brush with abrasive fiber, and other small brushes.
- Adopt high-speed machine head system. Speed reaches 7 holes per second.
- Equipped with a worktable 2 stations, machine works in continuous cycle, high efficiency.
- Single color and double colors are optional.
- Touch screen control system, Chinese and English versions, flexible and convenient operation.
- With insert, division, array, offset, modify and other functions, easy to program.
- Can save 128 different brushes programs, support external USB.
- Tufting accessories are standardized designs, durable, and easy to repair and replace.
- Machine got CE approved.

# 四轴单头高速植毛机

## 4 Axis Single Head High Speed Tufting Machine

型号 Model:  
GSJ50HM-SF4AGB



| 技术参数 Technical Parameters            |                                 |
|--------------------------------------|---------------------------------|
| 型号 Model                             | GSJ50HM-SF4AGB                  |
| 轴数 Axes                              | 4                               |
| 夹具 Fixture                           | 1 / 2                           |
| 植毛方式 Tufting Type                    | 马钉 Stapling wire                |
| 速度 Speed (r/min)                     | 450                             |
| 出锋 Length of fiber outside hole (mm) | 17 ~ 50                         |
| 毛长 Total length of fiber (mm)        | 40 ~ 110                        |
| 孔径 Diameter of hole (mm)             | 2.8 ~ 6.5                       |
| 毛的直径 Diameter of fiber (mm)          | 0.07 ~ 1.5mm                    |
| 颜色 Color                             | 双色 Double colors                |
| 总功率 Total power (KW)                 | 3                               |
| 额定电压 Voltage (V)                     | 380V / 220V                     |
| 气压 Air consumption (mpa.)            | 0.4 - 0.6                       |
| 尺寸 Dimensions (L x W x H cm)         | 104 x 91 x 180<br>41 x 35 x 104 |
| 重量 Net weight (kgs)                  | 450                             |

## 机器特性

- 本机特别适用于生产磨料丝烧烤刷，以及其它短小型毛刷等。
- 机头采用高速系统，植毛速度可高达 7 孔每秒。
- 配合工作台双工位，实现循环切换工件，提高工作效率。
- 单、双色植毛可任意选择。
- 人机触摸屏控制系统，操作灵活方便。
- 具有插孔，分孔，阵列，偏移，修改等多种编辑功能，编程简单快捷。
- 可存放 128 款不同刷子程序，支持外接 USB。
- 植毛配件均采用标准化设计，实现多工序加工，光洁耐用，便于更换。
- 产品已获得欧盟 CE 认证。

## Machine Features

- Especially for pre-hole grill / BBQ brushes with abrasive fiber, and other small brushes.
- Adopt high-speed machine head system. Speed reaches 7 holes per second.
- Equipped with a worktable 2 stations, machine works in continuous cycle, high efficiency.
- Single color and double colors are optional.
- Touch screen control system, Chinese and English versions, flexible and convenient operation.
- With insert, division, array, offset, modify and other functions, easy to program.
- Can save 128 different brushes programs, support external USB.
- Tufting accessories are standardized designs, durable, and easy to repair and replace.
- Machine got CE approved.



# 五轴单头高速植毛机

## 5 Axis Single Head High Speed Tufting Machine

型号 Model:  
GZW-130/180-SF5A



| 技术参数 Technical Parameters            |                                  |                                  |
|--------------------------------------|----------------------------------|----------------------------------|
| 型号 Model                             | GZW-130-SF5A                     | GZW-180-SF5AL                    |
| 轴数 Axes                              | 5                                | 5                                |
| 夹具 Fixture                           | 2                                | 2                                |
| 植毛方式 Tufting Type                    | 扁线 Flat wire / 马钉 Stapling wire  |                                  |
| 速度 Speed (r/min)                     | 450                              | 420                              |
| 出锋 Length of fiber outside hole (mm) | 17 ~ 130                         | 17 ~ 180                         |
| 毛长 Total length of fiber (mm)        | 40 ~ 270                         | 40 ~ 400                         |
| 孔径 Diameter of hole (mm)             | 2.0 ~ 5.0 / 2.8 ~ 6.5            |                                  |
| 毛的直径 Diameter of fiber (mm)          | 0.07 ~ 1.5mm                     | 0.07 ~ 1.5mm                     |
| 颜色 Color                             | 双色 Double colors                 | 双色 Double colors                 |
| 总功率 Total power (KW)                 | 4.3                              | 4.3                              |
| 额定电压 Voltage (V)                     | 380V / 220V                      | 380V / 220V                      |
| 气压 Air consumption (mpa.)            | 0.4 - 0.6                        | 0.4 - 0.6                        |
| 尺寸 Dimensions (L x W x H cm)         | 120 x 108 x 200<br>41 x 41 x 122 | 120 x 108 x 210<br>41 x 41 x 122 |
| 重量 Net weight (kgs)                  | 550                              | 550                              |

## 机器特性

- 可更换不同的平台和夹具生产各种规则和不规则形状的刷子，如扫把，厕所刷，曲辊球刷等。
- 机头采用高速植毛系统，植毛速度可高达 7 孔每秒。
- 配合工作台双工位，实现循环切换工件，提高工作效率。
- 单、双色植毛可任意选择。
- 中英双语系统，操作灵活方便。
- 具有插孔，分孔，偏移，修改等多种编辑功能，编程简单快捷。
- 可存放 100 多款不同刷子程序，支持外接 USB。
- 植毛配件均采用标准化设计，实现多工序加工，光洁耐用，便于更换。
- 产品已获得欧盟 CE 认证。

## Machine Features

- Can be replaced by different platforms and fixtures to produce a variety of pre-hole regular-shape and irregular-shape brushes, such as broom, toilet brush, double hockey brush, etc.
- Adopt high-speed machine head system. Speed reaches 7 holes per second.
- Equipped with a worktable 2 stations, machine works in continuous cycle, high efficiency.
- Single color and double colors are optional.
- Chinese and English versions, flexible and convenient operation.
- With insert, division, offset, modify and other functions, easy to program.
- Can save more than 100 different brushes programs, support external USB.
- Tufting accessories are standardized designs, durable, and easy to repair and replace.
- Machine got CE approved.

# 二轴三头钻植一体机

## 2 Axis 3 Head Drilling and Filling Machine

型号 Model:  
FJL-130MD2/180MD2-SF2A3H



| 技术参数 Technical Parameters            |                                  |                                  |
|--------------------------------------|----------------------------------|----------------------------------|
| 型号 Model                             | FJL-130MD2-SF2A3H                | FJL-180MD2-SF2A3HL               |
| 轴数 Axes                              | 2                                | 2                                |
| 夹具 Fixture                           | 3                                | 3                                |
| 植毛方式 Tufting Type                    | 马钉 Stapling wire                 |                                  |
| 速度 Speed (r/min)                     | 450                              | 420                              |
| 出锋 Length of fiber outside hole (mm) | 17 ~ 130                         | 17 ~ 180                         |
| 毛长 Total length of fiber (mm)        | 40 ~ 270                         | 40 ~ 400                         |
| 孔径 Diameter of hole (mm)             | 2.8 ~ 6.5                        | 2.8 ~ 8.0                        |
| 毛的直径 Diameter of fiber (mm)          | 0.07 ~ 1.5mm                     |                                  |
| 颜色 Color                             | 双色 Double colors                 |                                  |
| 总功率 Total power (KW)                 | 5                                | 5                                |
| 额定电压 Voltage (V)                     | 380V / 220V                      | 380V / 220V                      |
| 气压 Air consumption (mpa.)            | 0.4 - 0.6                        | 0.4 - 0.6                        |
| 尺寸 Dimensions (L x W x H cm)         | 155 x 125 x 186<br>41 x 35 x 104 | 155 x 125 x 196<br>41 x 35 x 104 |
| 重量 Net weight (kgs)                  | 1000                             | 1000                             |

## 机器特性

- 本机两钻一植的设计，配合工作台三个工位三个夹具，实现循环切换工件，提高工作效率。
- 本机适用于制造各种平面毛刷，如洗衣刷，浴刷，平板清洁刷等毛刷。
- 机头采用高速系统，植毛速度可高达 450r/m。
- 单、双色植毛可任意选择。
- 人机触摸屏控制系统，操作灵活方便。
- 支持同步钻植、单钻孔、单植毛等加工模式。
- 具有插孔，分孔，阵列，偏移，修改等多种编辑功能，编程简单快捷。
- 可存放 128 款不同刷子程序，支持外接 USB。
- 植毛配件均采用标准化设计，实现多工序精加工，光洁耐用，便于更换。
- 产品已获得欧盟 CE 认证。

## Machine Features

- Designed by 2 drillings and 1 tufting, equipped with 3 stations 3 fixtures, machine works in continuous cycle, high efficiency.
- Suitable for brushes in flat shape, such as scrub brush, bath brush, block brush and so on.
- Adopt high-speed machine head system. Speed reaches 450r/m.
- Single color and double colors are optional.
- Touch screen control system, Chinese and English version, flexible and convenient operation.
- Support synchronous drilling and tufting, single drilling, single tufting and other processing modes.
- With insert, division, array, offset, modify and other functions, easy to program.
- Can save 128 different brushes programs, support external USB.
- Tufting accessories are standardized designs, achieve multi-process finishing, beautiful and durable.
- Machine got CE approved.



# 五轴三头钻植一体机

## 5 Axis 3 Head Drilling and Filling Machine

型号 Model:  
FJL-130MD5/180MD5-SF5A3H

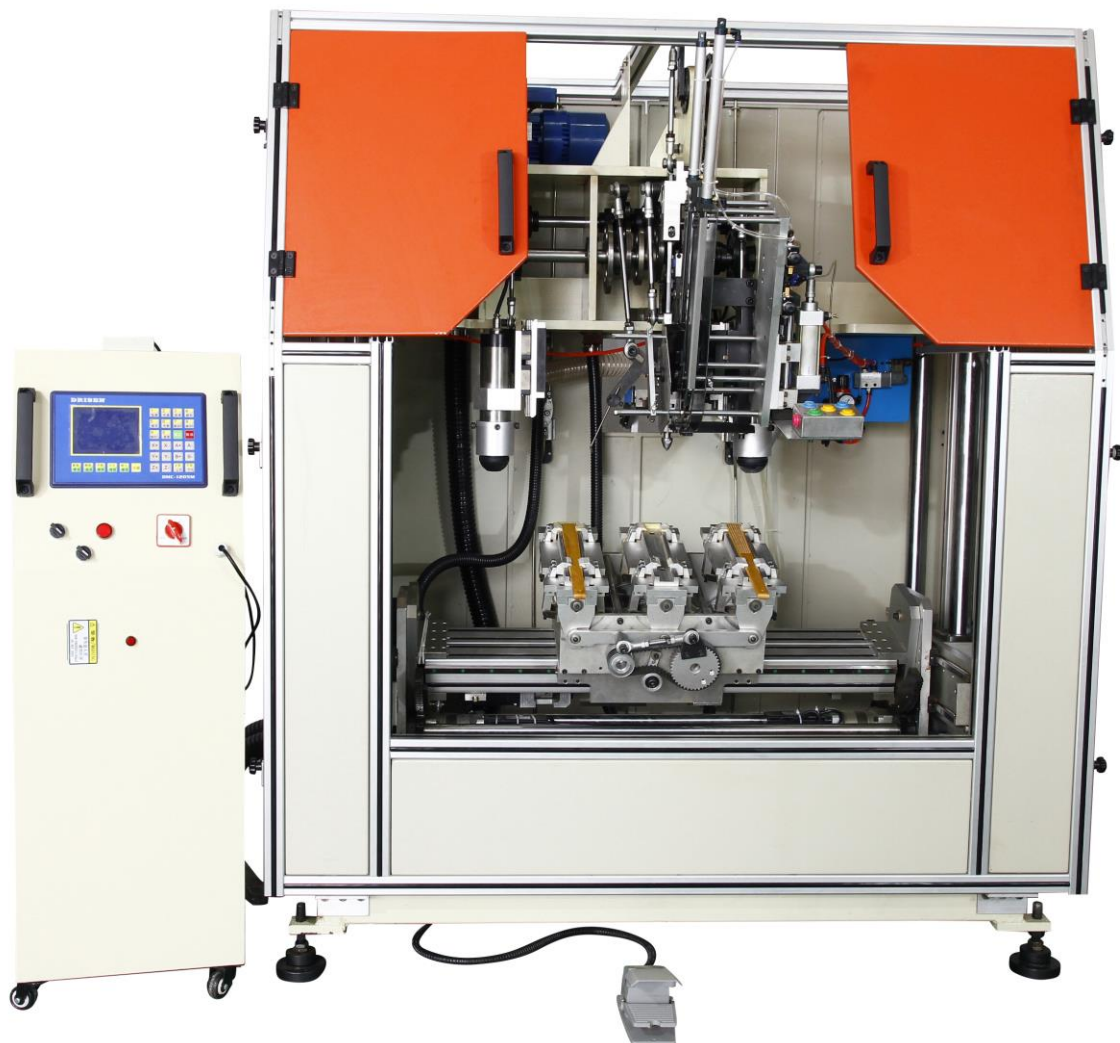

| 技术参数 Technical Parameters            |                                  |                                  |
|--------------------------------------|----------------------------------|----------------------------------|
| 型号 Model                             | FJL-130MD5-SF5A3H                | FJL-180MD5-SF5A3HL               |
| 轴数 Axes                              | 5                                | 5                                |
| 夹具 Fixture                           | 3                                | 3                                |
| 植毛方式 Tufting Type                    | 马钉 Stapling wire                 |                                  |
| 速度 Speed (r/min)                     | 450                              | 420                              |
| 出锋 Length of fiber outside hole (mm) | 17 ~ 130                         | 17 ~ 180                         |
| 毛长 Total length of fiber (mm)        | 40 ~ 270                         | 40 ~ 400                         |
| 孔径 Diameter of hole (mm)             | 2.8 ~ 6.5                        | 2.8 ~ 8.0                        |
| 毛的直径 Diameter of fiber (mm)          | 0.07 ~ 1.5mm                     |                                  |
| 颜色 Color                             | 双色 Double colors                 |                                  |
| 总功率 Total power (KW)                 | 7.5                              | 7.5                              |
| 额定电压 Voltage (V)                     | 380V / 220V                      | 380V / 220V                      |
| 气压 Air consumption (mpa.)            | 0.4 - 0.6                        | 0.4 - 0.6                        |
| 尺寸 Dimensions (L x W x H cm)         | 160 x 125 x 200<br>41 x 41 x 122 | 160 x 125 x 210<br>41 x 41 x 122 |
| 重量 Net weight (kgs)                  | 1100                             | 1100                             |

## 机器特性

- 本机两钻一植的设计，配合工作台三个工位三个夹具，实现循环切换工件，提高工作效率。
- 可更换不同的平台和夹具生产各种平面、弧面、曲面等规则或不规则的刷子，如扫把，厕所刷，曲辊球刷等。
- 机头采用高速系统，植毛速度可高达 450r/m。
- 单、双色植毛可任意选择。
- 中英双语系统，操作灵活方便。
- 具有插孔，分孔，偏移，修改等多种编辑功能，编程简单快捷。
- 可存放 100 多款不同刷子程序，支持外接 USB。
- 植毛配件均采用标准化设计，实现多工序加工，光洁耐用，便于更换。
- 产品已获得欧盟 CE 认证。

## Machine Features

- Designed by 2 drillings and 1 tufting, equipped with 3 stations 3 fixtures, machine works in continuous cycle, high efficiency.
- Optional round, flat or roller platforms for different types of brushes, such as broom, round toilet brush, double hockey brush, shoes brush and so on.
- Adopt high-speed machine head system. Speed reaches 450r/m.
- Single color and double colors are optional.
- Chinese and English versions, flexible and convenient operation.
- With insert, division, offset, modify and other functions, easy to program.
- Can save more than 100 different brushes programs, support external USB.
- Tufting accessories are standardized designs, achieve multi-process finishing, beautiful and durable.
- Machine got CE approved.

# 二轴单头植毛机

## 2 Axis Single Head Tufting Machine

型号 Model:  
A1230-LS2A1TR



| 技术参数 Technical Parameters            |                                    |
|--------------------------------------|------------------------------------|
| 型号 Model                             | A1230-LS2A1TR                      |
| 轴数 Axes                              | 2                                  |
| 夹具 Fixture                           | 2 / 4                              |
| 植毛方式 Tufting Type                    | 马钉 Stapling wire                   |
| 速度 Speed (r/min)                     | 360                                |
| 出锋 Length of fiber outside hole (mm) | 12 ~ 35                            |
| 毛长 Total length of fiber (mm)        | 30 ~ 80                            |
| 孔径 Diameter of hole (mm)             | 2.2 ~ 5.0                          |
| 毛的直径 Diameter of fiber (mm)          | 0.07 ~ 1.2mm                       |
| 颜色 Color                             | 单色 Single color / 双色 Double colors |
| 总功率 Total power (KW)                 | 2                                  |
| 额定电压 Voltage (V)                     | 380V / 220V                        |
| 气压 Air consumption (mpa.)            | 0.4 - 0.6                          |
| 尺寸 Dimensions (L x W x H cm)         | 85 x 90 x 160<br>41 x 35 x 104     |
| 重量 Net weight (kgs)                  | 350                                |

## 机器特性

- 本机特别适用于生产各种平面的钢丝刷，文玩刷，染发刷，和其它短小型毛刷等。
- 此植毛系统特别适用于孔径较小，出锋较短的毛刷，以及以钢丝，铜丝，猪鬃，剑麻等动植物毛为毛料的刷子。
- 配合工作台双工位，实现循环切换工件，提高工作效率。植毛速度可达 5-6 孔每秒。
- 单、双色植毛可任意选择。
- 人机触摸屏控制系统，操作灵活方便。
- 具有插孔，分孔，阵列，偏移，修改等多种编辑功能，编程简单快捷。
- 可存放 128 款不同刷子程序，支持外接 USB。
- 产品已获得欧盟 CE 认证。

## Machine Features

- Special for pre-hole brushes in flat shape. Such as wire brush, bristle brush, hair dye brush, and other small brushes.
- This tufting system is especially suitable for brushes with small hole diameter and short fiber length, as well as brushes with fiber of stainless steel wire, copper wire, pig bristle, wool, horse hair, Tampico fiber and other animal hair and natural fiber.
- Equipped with a worktable 2 stations, machine works in continuous cycle, high efficiency. Speed reaches 5-6 holes per second.
- Single color and double colors are optional.
- Touch screen control system, Chinese and English versions, flexible and convenient operation.
- With insert, division, array, offset, modify and other functions, easy to program.
- Can save 128 different brushes programs, support external USB.
- Machine got CE approved.



# 三轴单头植毛机

## 3 Axis Single Head Tufting Machine

型号 Model:  
A1330-LS3A1TR

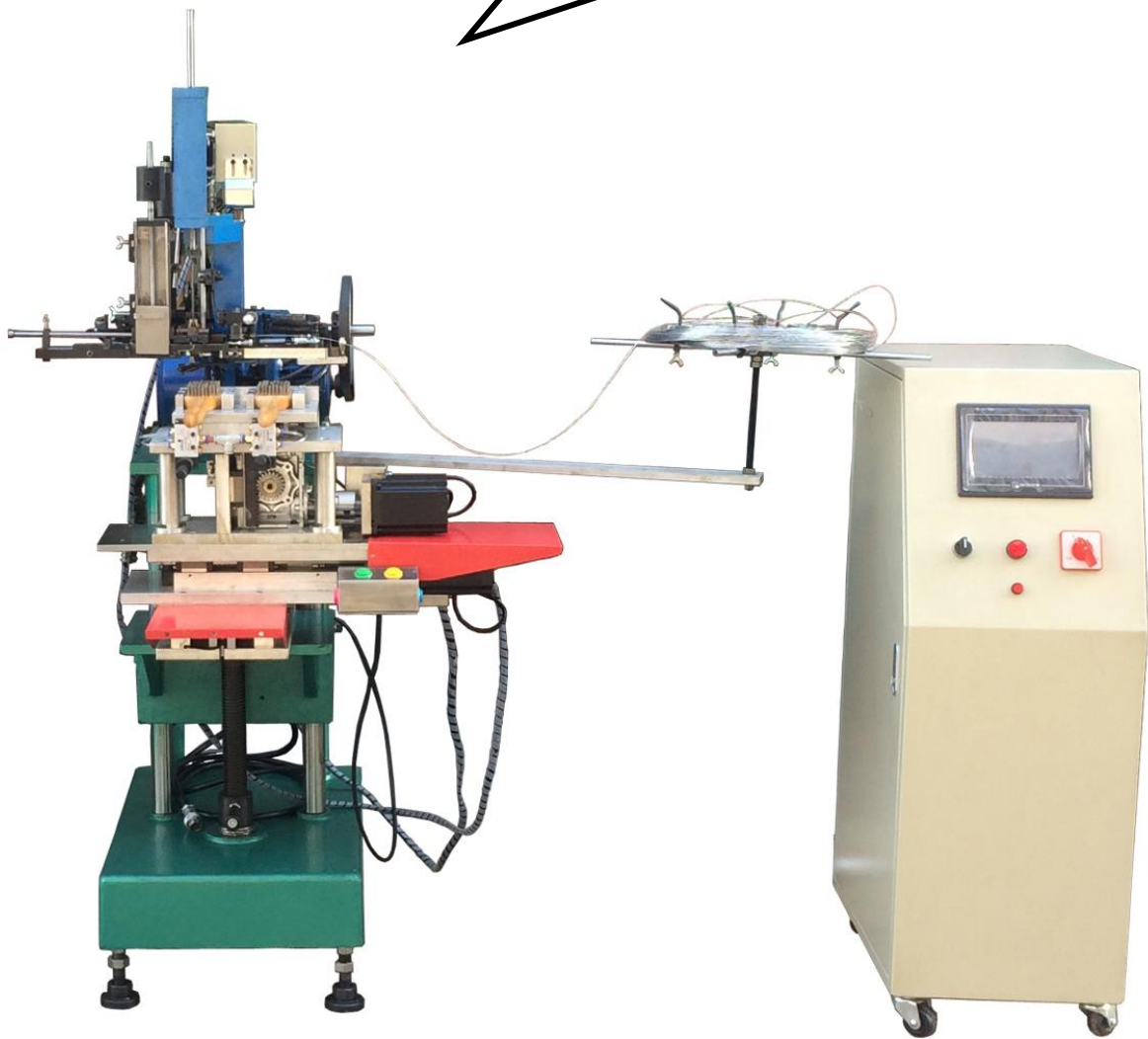

| 技术参数 Technical Parameters            |                                    |
|--------------------------------------|------------------------------------|
| 型号 Model                             | A1330-LS3A1TR                      |
| 轴数 Axes                              | 3                                  |
| 夹具 Fixture                           | 2                                  |
| 植毛方式 Tufting Type                    | 马钉 Stapling wire                   |
| 速度 Speed (r/min)                     | 360                                |
| 出锋 Length of fiber outside hole (mm) | 12 ~ 35                            |
| 毛长 Total length of fiber (mm)        | 30 ~ 80                            |
| 孔径 Diameter of hole (mm)             | 2.2 ~ 5.0                          |
| 毛的直径 Diameter of fiber (mm)          | 0.07 ~ 1.2mm                       |
| 颜色 Color                             | 单色 Single color / 双色 Double colors |
| 总功率 Total power (KW)                 | 2.8                                |
| 额定电压 Voltage (V)                     | 380V / 220V                        |
| 气压 Air consumption (mpa.)            | 0.4 - 0.6                          |
| 尺寸 Dimensions (L x W x H cm)         | 85 x 90 x 160<br>41 x 35 x 104     |
| 重量 Net weight (kgs)                  | 350                                |

## 机器特性

- 本机特别适用于生产各种平面和弧面的钢丝刷，烧烤刷，石米刷，洗面刷，洗脚刷，和其它短小型毛刷等。
- 此植毛系统特别适用于孔径较小，出锋较短的毛刷，以及以钢丝，铜丝，猪鬃，剑麻等动植物毛为毛料的刷子。
- 配合工作台双工位，实现循环切换工件，提高工作效率。植毛速度可达 5-6 孔每秒。
- 单、双色植毛可任意选择。
- 人机触摸屏控制系统，操作灵活方便。
- 具有插孔，分孔，阵列，偏移，修改等多种编辑功能，编程简单快捷。
- 可存放 128 款不同刷子程序，支持外接 USB。
- 产品已获得欧盟 CE 认证。

## Machine Features

- Special for pre-hole brushes in flat and curved shape. Such as wire brush, grill brush, bristle brush, face wash brush, foot scrubbing brush, and other small brushes.
- This tufting system is especially suitable for brushes with small hole diameter and short fiber length, as well as brushes with fiber of stainless steel wire, copper wire, pig bristle, wool, horse hair, Tampico fiber and other animal hair and natural fiber.
- Equipped with a worktable 2 stations, machine works in continuous cycle, high efficiency. Speed reaches 5-6 holes per second.
- Single color and double colors are optional.
- Touch screen control system, Chinese and English versions, flexible and convenient operation.
- With insert, division, array, offset, modify and other functions, easy to program.
- Can save 128 different brushes programs, support external USB.
- Machine got CE approved.

# 二轴三头钻植一体机

## 2 Axis 3 Head Drilling and Tufting Machine

型号 Model:  
JXF-35MD2-LS2A3H



| 技术参数 Technical Parameters            |                                    |
|--------------------------------------|------------------------------------|
| 型号 Model                             | JXF-35MD2-LS2A3H                   |
| 轴数 Axes                              | 2                                  |
| 夹具 Fixture                           | 3                                  |
| 植毛方式 Tufting Type                    | 马钉 Stapling wire                   |
| 速度 Speed (r/min)                     | 360                                |
| 出锋 Length of fiber outside hole (mm) | 12 ~ 35                            |
| 毛长 Total length of fiber (mm)        | 30 ~ 80                            |
| 孔径 Diameter of hole (mm)             | 2.2 ~ 5.0                          |
| 毛的直径 Diameter of fiber (mm)          | 0.07 ~ 1.2mm                       |
| 颜色 Color                             | 单色 Single color / 双色 Double colors |
| 总功率 Total power (KW)                 | 5                                  |
| 额定电压 Voltage (V)                     | 380V / 220V                        |
| 气压 Air consumption (mpa.)            | 0.4 - 0.6                          |
| 尺寸 Dimensions (L x W x H cm)         | 125 x 90 x 160<br>41 x 35 x 104    |
| 重量 Net weight (kgs)                  | 450                                |

## 机器特性

- 本机特别适用于生产各种平面的钢丝刷，文玩刷，鞋刷，浴刷和其它短小型毛刷等。
- 此植毛系统特别适用于孔径较小，出锋较短的毛刷，以及以钢丝，铜丝，猪鬃，剑麻等动植物毛为毛料的刷子。
- 配合工作台双工位，实现循环切换工件，提高工作效率。植毛速度可达 5-6 孔每秒。
- 单、双色植毛可任意选择。
- 人机触摸屏控制系统，操作灵活方便。
- 具有插孔，分孔，阵列，偏移，修改等多种编辑功能，编程简单快捷。
- 可存放 128 款不同刷子程序，支持外接 USB。
- 产品已获得欧盟 CE 认证。

## Machine Features

- Special for pre-hole brushes in flat shape. Such as wire brush, bristle brush, shoes brush, bath brush and other small brushes.
- This tufting system is especially suitable for brushes with small hole diameter and short fiber length, as well as brushes with fiber of stainless steel wire, copper wire, pig bristle, wool, horse hair, Tampico fiber and other animal hair and natural fiber.
- Equipped with a worktable 2 stations, machine works in continuous cycle, high efficiency. Speed reaches 5-6 holes per second.
- Single color and double colors are optional.
- Touch screen control system, Chinese and English versions, flexible and convenient operation.
- With insert, division, array, offset, modify and other functions, easy to program.
- Can save 128 different brushes programs, support external USB.
- Machine got CE approved.



# 三轴三头钻植一体机

## 3 Axis 3 Head Drilling and Tufting Machine

型号 Model:  
JXF-35MD3-LS3A3H

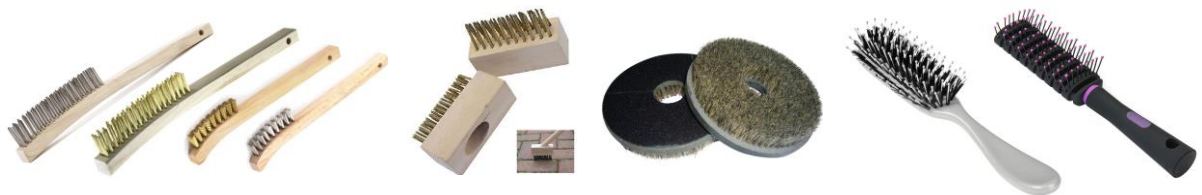

| 技术参数 Technical Parameters            |                                    |
|--------------------------------------|------------------------------------|
| 型号 Model                             | JXF-35MD3-LS3A3H                   |
| 轴数 Axes                              | 3                                  |
| 夹具 Fixture                           | 3                                  |
| 植毛方式 Tufting Type                    | 马钉 Stapling wire                   |
| 速度 Speed (r/min)                     | 360                                |
| 出锋 Length of fiber outside hole (mm) | 12 ~ 35                            |
| 毛长 Total length of fiber (mm)        | 30 ~ 80                            |
| 孔径 Diameter of hole (mm)             | 2.2 ~ 5.0                          |
| 毛的直径 Diameter of fiber (mm)          | 0.07 ~ 1.2mm                       |
| 颜色 Color                             | 单色 Single color / 双色 Double colors |
| 总功率 Total power (KW)                 | 5.8                                |
| 额定电压 Voltage (V)                     | 380V / 220V                        |
| 气压 Air consumption (mpa.)            | 0.4 - 0.6                          |
| 尺寸 Dimensions (L x W x H cm)         | 125 x 90 x 160<br>41 x 35 x 104    |
| 重量 Net weight (kgs)                  | 450                                |

## 机器特性

- 本机特别适用于生产各种平面和弧面的钢丝刷，头梳，石米刷和其它短小型毛刷等。
- 此植毛系统特别适用于孔径较小，出锋较短的毛刷，以及以钢丝，铜丝，猪鬃，剑麻等动植物毛为毛料的刷子。
- 配合工作台双工位，实现循环切换工件，提高工作效率。植毛速度可达 5-6 孔每秒。
- 单、双色植毛可任意选择。
- 人机触摸屏控制系统，操作灵活方便。
- 具有插孔，分孔，阵列，偏移，修改等多种编辑功能，编程简单快捷。
- 可存放 128 款不同刷子程序，支持外接 USB。
- 产品已获得欧盟 CE 认证。

## Machine Features

- Special for pre-hole brushes in flat and curved shape. Such as wire brush, hair brush, block brush, bristle brush, and other small brushes.
- This tufting system is especially suitable for brushes with small hole diameter and short fiber length, as well as brushes with fiber of stainless steel wire, copper wire, pig bristle, wool, horse hair, Tampico fiber and other animal hair and natural fiber.
- Equipped with a worktable 2 stations, machine works in continuous cycle, high efficiency. Speed reaches 5-6 holes per second.
- Single color and double colors are optional.
- Touch screen control system, Chinese and English versions, flexible and convenient operation.
- With insert, division, array, offset, modify and other functions, easy to program.
- Can save 128 different brushes programs, support external USB.
- Machine got CE approved.

# 三轴头梳钻植一体机

## 3 Axis Hair Brush Drilling and Tufting Machine

型号 Model:  
TS-30BX-LSHB3A2HF



| 技术参数 Technical Parameters            |                                |
|--------------------------------------|--------------------------------|
| 型号 Model                             | TS-30BX-LSHB3A2HF              |
| 轴数 Axes                              | 3                              |
| 夹具 Fixture                           | 4                              |
| 植毛方式 Tufting Type                    | 扁线 Flat wire                   |
| 速度 Speed (r/min)                     | 360                            |
| 出锋 Length of fiber outside hole (mm) | 12 ~ 35                        |
| 毛长 Total length of fiber (mm)        | 30 ~ 80                        |
| 孔径 Diameter of hole (mm)             | 2.2 ~ 5.0                      |
| 毛的直径 Diameter of fiber (mm)          | 0.07 ~ 1.2mm                   |
| 颜色 Color                             | 双色 Double colors               |
| 总功率 Total power (KW)                 | 4.3                            |
| 额定电压 Voltage (V)                     | 380V / 220V                    |
| 气压 Air consumption (mpa.)            | 0.4 - 0.6                      |
| 尺寸 Dimensions (L x W x H cm)         | 90 x 90 x 150<br>41 x 35 x 104 |
| 重量 Net weight (kgs)                  | 400                            |

## 机器特性

- 本机专为圆辊型头梳设计的一款钻孔植毛一体机。
- 配合工作台四个工位四个夹具，实现循环切换工件，提高工作效率。植毛速度可达 5-6 孔每秒。
- 此植毛系统设置双料毛箱，可实现单条尼龙丝和猪鬃混合植入同一孔内。
- 本系统为扁线植毛系统。
- 人机触摸屏控制系统，操作灵活方便。
- 具有插孔，分孔，阵列，偏移，修改等多种编辑功能，编程简单快捷。
- 可存放 128 款不同刷子程序，支持外接 USB。
- 产品已获得欧盟 CE 认证。

## Machine Features

- Designed by 1 drilling and 1 tufting, special for round hair brushes with wooden handle.
- Equipped with a worktable 4 stations, machine works in continuous cycle, high efficiency. Speed reaches 5-6 holes per second.
- This tufting system is equipped with double bristle boxes, which allows a single nylon filament and pig bristle to be mixed filled into the same hole.
- It's flat wire tufting system.
- Touch screen control system, Chinese and English versions, flexible and convenient operation.
- With insert, division, array, offset, modify and other functions, easy to program.
- Can save 128 different brushes programs, support external USB.
- Machine got CE approved.

型号 Model: AM-MTM1



**简易手动飞毛机**  
**Manual Trimming Machine**

- 适合修剪平面毛刷。  
Suitable for flat brushes.
- 手动式平毛功能。  
Manual type, trimming function.

型号 Model: AM-ATM5

**球型刷自动飞毛机**  
**Automatic Toilet Brush Trimming Machine**

- 适合修剪球状的刷子。  
Suitable for spherical brushes.
- 自动平毛功能。  
Automatic-type, trimming function.



型号 Model: AM-ATNF7

**平面扫把自动飞毛开花机**  
**Automatic Flat Broom Trimming and Flagging Machine**

- 只适合平面的扫把和刷子，刷丝末端作平整修剪。  
Suitable for brooms/brushes in flat shape. The ending of fiber is straight.
- 自动直链式平毛开花功能。  
Automatic type, trimming and flagging functions.







型号 Model: AM-CT60

### 气动切毛机

#### Pneumatic Fiber Cutting Machine

- 用于将毛料切断。  
Used to cut filaments.
- 每捆刷丝直径不超 60mm。  
Bundle diameter: 60mm
- 适用于 PP, PVC, PET, 尼龙等各种塑料毛料, 动植物毛。  
Material of filaments: Plastic, PP, PVC, PET, nylon, animal hair, etc.



型号 Model: AM-ATNF6

### 旋转式自动飞毛开花机

#### Rotary-type Automatic Trimming and Flagging Machine

- 适合不同形状的刷子, 刷丝末端加工可平整, 可倾斜, 可带弧度。  
Suitable for brushes in flat or curved shape. The ending of fiber can be straight, slant and curved.
- 刷柄长度不超 400mm, 刷丝见光不超 150mm。  
Length of brush base: Max. 400mm.  
Length of filament outside hole: Max. 150mm.



型号 Model: AM-ATM8

### 辊刷自动飞毛机

#### Automatic Cylinder Brush Trimming Machine

- 适合修剪圆辊刷。  
Suitable for cylinder brushes / roller brushes.
- 辊刷外径不超 600mm, 辊刷长度不超 1000mm (可定做)。  
Outer diameter of brush: Max. 600mm. Length of brush: 1000mm (customized).





**佛山市鑫泰丰机械有限公司**

地址：中国佛山市南海区罗村下柏第二工业区前进路11号A9 邮编：528226

电话：+86 0757 86407589

传真：+86 0757 86407583

手机/微信：+86 135 3436 2271

邮箱：935706725@qq.com

网站：www.gd-tfl.com

**TOPSTAR CNC BRUSH MACHINE LIMITED**

A9, NO.11 QianJin Road, XiaBai Industrial Zone II, Luocun Naihai District, Foshan City, 528226 CHINA

Tel : +86 757 86408583

Fax: +86 757 86407583

Mob/Wechat/WhatsApp: +86 181 2274 6004

E-mail: cncbrushmachine@hotmail.com

Web: <https://www.cncbrushmachine.com>